

Monday, April 9, 2007, the Sabine County Commissioners' Court met in regular session. The following members of Court were present:

Charles Watson	County Judge
Keith Clark	Commissioner Pct. #1
Jimmy McDaniel	Commissioner Pct. #2
Doyle Dickerson	Commissioner Pct. #3
Fayne Warner	Commissioner Pct. #4
Janice McDaniel	County Clerk

Judge Watson called the meeting to order and Commissioner Dickerson led the Court in prayer.

Agenda item #1-General Business

Commissioner Clark moved to approve the minutes as written for the March 26<sup>th</sup> regular session of Court. Commissioner McDaniel seconded. All voted for. Motion carried.

Agenda item #2-Line Item Transfers

No line item transfers were submitted.

Agenda item #3-Approve Reports

Commissioner Clark moved to accept the reports from County Agent, Amanda Drennon and the Tax Office. Commissioner Warner seconded. All voted for. Motion carried.

Agenda item #4-James Lawson to Address Court on HELP

Mr. Lawson is not in Court. No action taken.

Agenda item #14-Recognize Martha Stone on Her Completion of the Open Meetings Act and Public Information Act Training

The Court recognized Martha Stone, Tax Assessor/Collector. See attached copies.

Agenda item #5-Discuss and Take Action on Depository Contract

Sabine State Bank and First State Bank, Hemphill submitted bids on the County depository. First Bank and Trust submitted a bid at 8:45 a.m., which was after the time advertised.

County Treasurer, Tricia Jacks, recommended accepting the bid from First State Bank, Hemphill.

Commissioner Clark moved to accept the 4 year contract with First State Bank, Hemphill with the option of to review in 2 years. Commissioner Dickerson seconded. All voted for. Motion carried.

Agenda item #6-Columbia Committee to Address Court

Belinda Gay, President of the Columbia Committee, met with the Court. They are asking the Court to consider purchasing property beside property owned by the City of Hemphill with the intent of leasing it to the Committee.

Commissioner Clark said he went to the meeting in Lufkin and he feels that State Officials are working toward getting a Memorial built in Sabine County.

The Court asked Ms. Gay to see if she could get a price on the property.

This item was tabled with no action taken.

Agenda item #8-Discuss and Possible Action on Eddings Lane

Commissioner Dickerson said what they want to do is cut a curve off. Mr. Eddings is giving the right-of-way and they will accept the expense to do this.

Commissioner Dickerson moved to accept the R-O-W easement. Commissioner Warner seconded. All voted for. Motion carried.

Agenda item #7-Approval of Payment on Air Conditioner for Sheriff's Office

Sheriff Maddox said he has 2 bids. They are as follows:

1. Doug's A/C \$5,650
2. Parker Refrigeration Services \$5,688

Sheriff Maddox said the bid from Doug's A/C does not include taking the present unit off and putting the new one on. The bid from Parker Refrigeration Services is a turn key job.

Commissioner McDaniel moved to accept the bid from Parker Refrigeration Services in the amount of \$5,688.00. Commissioner Dickerson seconded. All voted for. Motion carried.

Agenda item #12-Patricia Bean to Address Court About "The Bean Burner"

Patricia Bean met with the Court asking that she be able to use her new invention "The Bean Burner" during the time that a burn ban has been put in place by the Court.

The Court said they will check this out. No action was taken today.

Agenda item #9-Discuss and Take Action on Purchase for Motor Grader for

Pct. 2 Commissioner Dickerson moved for Court approval for Precinct 2 to purchase a John Deere motor grader for \$122,000.00. Commissioner Clark seconded. All voted for. Motion carried.

VOL TT PG 723

Court recessed at 9:00 for the public hearing on "Eagle Estates Subdivision".  
Court reconvened into regular session.

Agenda item #11-Discuss and Take Action on Eagle Estate Subdivision

Commissioner Clark moved to accept the roads in Eagle Estate Subdivision for County maintenance. Commissioner McDaniel seconded. All voted for. Motion carried.

Agenda item #13-Discuss and Possible Action on County Divide Road

Commissioner Dickerson said County Divide road was formerly known as County Line road. The water is running across the road and the ditches need cleaned out to stop it. He said he has gotten permission from Mr. Miller to get on his property so he can clean the ditches out.

Commissioner Dickerson moved for Court permission to allow him to get on Mr. Miller's property to clean the ditches out. Commissioner Clark seconded. All voted for. Motion carried.

Agenda item #10-Discuss and Possible Action on Advertising for Bids to Sale Dura Patcher Model 125JDT with 300 Gallon Oil Tank in Pct. 2

Commissioner McDaniel moved to advertise to sale the surplus equipment. Commissioner Dickerson seconded. All voted for. Motion carried. See attached copy.

Agenda item #15-Pay Accounts and Salaries

Commissioner Clark moved to pay the accounts and salaries. Commissioner McDaniel seconded. All voted for. Motion carried

Commissioner Warner moved to adjourn. Commissioner Dickerson seconded. All voted for. Meeting adjourned.

Charles E. Watson CHARLES WATSON

Keith Clark KEITH CLARK

Jimmy McDaniel JIMMY MCDANIEL

Doyle Dickerson DOYLE DICKERSON

Fayne Warner FAYNE WARNER

ATTEST: COUNTY CLERK

Janice McDaniel JANICE MCDANIEL

GENERAL FUND

AP Vendor Detail Ledger (Unpaid Invoices - Payment Detail)

Ledger as of: 4/30/2007

Invoice Number Description	Inv.Date	Tms.Date Account	Due.Date	Amount	Discount	Amount Paid	Check Date	Check Number	Bank	Balance
<b>BASS BASS COMPUTERS, INC.</b>										
SI-607057	03/20/07	04/05/07	05/04/07							
EXTREME 430 WT SINGLE FAN		6500.560		\$37.50						\$37.50
FREIGHT		6500.560		\$8.16						\$8.16
INVOICE SI-607057 TOTALS:				\$45.66	\$0.00	\$0.00				\$45.66
<b>S1-604107</b>										
MAN 6FT SVGA CABLE W/FERRITE	04/01/07	04/05/07	05/16/07							
FREIGHT		6500.560		\$4.99						\$4.99
		6500.560		\$7.64						\$7.64
INVOICE S1-604107 TOTALS:				\$12.63	\$0.00	\$0.00				\$12.63
<b>BASS COMPUTERS, INC. TOTALS:</b>				<b>\$58.29</b>	<b>\$0.00</b>	<b>\$0.00</b>				<b>\$58.29</b>
<b>BEIN BEARD'S INTERNET</b>										
040507	04/05/07	04/05/07	05/20/07							
INTERNET SERVICE FOR APRIL		6310.403		\$19.95						\$19.95
INVOICE 040507 TOTALS:				\$19.95	\$0.00	\$0.00				\$19.95
<b>BEARD'S INTERNET TOTALS:</b>				<b>\$19.95</b>	<b>\$0.00</b>	<b>\$0.00</b>				<b>\$19.95</b>
<b>CAPO CARLA YVETTE POWELL</b>										
MARCH232007	03/23/07	04/05/07	05/07/07							
JURY COMMISSIONER		6532.435		\$10.00						\$10.00
INVOICE MARCH232007 TOTALS:				\$10.00	\$0.00	\$0.00				\$10.00
<b>CARLA YVETTE POWELL TOTALS:</b>				<b>\$10.00</b>	<b>\$0.00</b>	<b>\$0.00</b>				<b>\$10.00</b>
<b>CHWA CHARLES WATSON</b>										
FEB&MARCH2007	04/02/07	04/05/07	05/17/07							
550 MILES @ .40 PER MILE		6441.400		\$220.00						\$220.00
INVOICE FEB&MARCH2007 TOTALS:				\$220.00	\$0.00	\$0.00				\$220.00
<b>CHARLES WATSON TOTALS:</b>				<b>\$220.00</b>	<b>\$0.00</b>	<b>\$0.00</b>				<b>\$220.00</b>
<b>CITY CITY OF HEMPHILL</b>										
031407	03/14/07	04/05/07	04/28/07							
TEXAS ST OLD JAIL ACC# 05-0331-00		6440.408		\$234.92						\$234.92
COURTHOUSE ACC# 05-0332-00		6440.408		\$338.90						\$338.90

VOL III PG 725

V - Denotes Voided Check Entries

GENERAL FUND

AP Vendor Detail Ledger (Unpaid Invoices - Payment Detail)  
Ledger as of : 4/30/2007

Invoice Number Description	Inv.Date	Trms.Date Account	Due.Date	Amount	Discount	Amount Paid	Check Date	Check Number	Bank	Balance
COURTHOUSE ACC# 05-0340-00		6440.408		\$152.84						\$152.84
201 MAIN CO COURTHOUSE ACC#05-0360-00		6440.408		\$121.24						\$121.24
NEW METER @ COURTHOUSE ACC# 05-0365-00		6440.408		\$212.28						\$212.28
ELEVATOR ACC# 05-0380-00		6440.408		\$213.73						\$213.73
235 TX ST/BEHIN JAIL ACC# 06-0018-00		6440.408		\$147.45						\$147.45
2213 MARKET ST(OLD POST) ACC# 06-0020-01		6440.408		\$238.81						\$238.81
OLD POST OFFICE ACC# 06-0025-00		6440.408		\$131.26						\$131.26
BEHIND COURTHOUSE ANNEX ACC# 06-0030-00		6440.408		\$76.60						\$76.60
INVOICE 031407 TOTALS:				\$1,868.03	\$0.00	\$0.00				\$1,868.03
031707	03/17/07	04/05/07	06/01/07							
310 MAIN ST (JAIL) ACC#06-0015-00		6440.560		\$2,495.42						\$2,495.42
BEHIND JAIL HOUSE ACC #06-0016-00		6440.560		\$8.01						\$8.01
INVOICE 031707 TOTALS:				\$2,503.43	\$0.00	\$0.00				\$2,503.43
CITY OF HEMPHILL TOTALS:				\$4,371.46	\$0.00	\$0.00				\$4,371.46
DCOG	DEEP EAST TX COUNCIL OF GOV									
033107	03/31/07	04/05/07	05/15/07							
DETCOG LUCHEON FOR DEAN CROCKETT		6427.400		\$6.00						\$6.00
INVOICE 033107 TOTALS:				\$6.00	\$0.00	\$0.00				\$6.00
DEEP EAST TX COUNCIL OF GOV TOTALS:				\$6.00	\$0.00	\$0.00				\$6.00
DIPA	DIXIE PAPER COMPANY									
965949-00	03/22/07	04/05/07	05/06/07							
1 ANGEL SOFT 2 PLY TISSUE 450/80		6313.560		\$55.95						\$55.95
STARBRITE LAUNDRY DETERGENT 50#PAIL		6313.560		\$39.00						\$39.00
INVOICE 965949-00 TOTALS:				\$94.95	\$0.00	\$0.00				\$94.95
967765-00	03/27/07	04/05/07	05/11/07							
1 CASCADE 8"X350' KRAFT2" CORE12RL		6310.408		\$23.56						\$23.56
4 DUTCH APPLE & SPICE METER AIR @ 3.99 EACH		6310.408		\$15.96						\$15.96
4 PACIFIC PEACH METERED AIR @ 3.99 EACH		6310.408		\$15.96						\$15.96
4 MANGO METERED AIR @ 3.99 EACH		6310.408		\$15.96						\$15.96

VOL III PG 724

\*V - Denotes Voided Check Entries

GENERAL FUND

AP Vendor Detail Ledger (Unpaid Invoices - Payment Detail)  
Ledger as of : 4/30/2007

Invoice Number Description	Inv.Date	Trns.Date Account	Due.Date	Amount	Discount	Amount Paid	Check Date	Check Number	Bank	Balance
INVOICE 967765-00 TOTALS:				\$71.44	\$0.00	\$0.00				\$71.44
968074-00	03/27/07	04/05/07	05/11/07							
1 CASE LIQUID BLEACH		6313.560		\$12.75						\$12.75
1 CASE CLEAN QUAT PINE CONCENTRATE		6313.560		\$22.48						\$22.48
8 OZ WHITE FOAM CUP		6313.560		\$18.94						\$18.94
DIXIE 38X58 WHITE SUPRTUFF 100CS		6313.560		\$29.95						\$29.95
ANGEL SOFT 2 PLY TISSUE 450/80		6313.560		\$55.95						\$55.95
INVOICE 968074-00 TOTALS:				\$140.07	\$0.00	\$0.00				\$140.07
968090-00	03/27/07	04/05/07	05/11/07							
1 DIXIE 38X58 WHITE SUPRTUFF 100CS		6310.408		\$28.77						\$28.77
INVOICE 968090-00 TOTALS:				\$28.77	\$0.00	\$0.00				\$28.77
DIXIE PAPER COMPANY TOTALS:				\$335.23	\$0.00	\$0.00				\$335.23
DOPD	DONOVAN PAUL DUDINSKY									
CAUSENO6300	03/23/07	04/05/07	05/07/07							
CAUSE NO 6300 STEVEN EDWARD WILLINGHAM		6531.435		\$350.00						\$350.00
INVOICE CAUSENO6300 TOTALS:				\$350.00	\$0.00	\$0.00				\$350.00
DONOVAN PAUL DUDINSKY TOTALS:				\$350.00	\$0.00	\$0.00				\$350.00
DUKE	DUANE F. KEATING									
939	03/29/07	04/05/07	05/13/07							
ANTHONY BOLTON DETENTION HEARING		6531.435		\$214.50						\$214.50
ANTHONY BOLTON DETENTION HEARING		6531.435		\$247.50						\$247.50
FEE		6531.435		(\$227.00)						(\$227.00)
FEE		6531.435		\$650.00						\$650.00
ANTHONY BOLTON HEARING ADJUDICATION		6531.435		\$165.00						\$165.00
INVOICE 939 TOTALS:				\$1,050.00	\$0.00	\$0.00				\$1,050.00
DUANE F. KEATING TOTALS:				\$1,050.00	\$0.00	\$0.00				\$1,050.00
EAWI	EARL L. WILLIS									
MARCH232007	03/23/07	04/05/07	05/07/07							
JURY COMMISSIONER		6532.435		\$10.00						\$10.00

VOL 11 PG 727

\*V - Denotes Voided Check Entries

GENERAL FUND

AP Vendor Detail Ledger (Unpaid Invoices - Payment Detail)  
Ledger as of : 4/30/2007

Invoice Number Description	Inv.Date	Trms.Date Account	Due.Date	Amount	Discount	Amount Paid	Check Date	Check Number	Bank	Balance
INVOICE MARCH232007 TOTALS:				\$10.00	\$0.00	\$0.00				\$10.00
EARL L. WILLIS TOTALS:				\$10.00	\$0.00	\$0.00				\$10.00
EJPR EUGENE J. PROCELLA, JR.										
008573	03/23/07	04/05/07	05/07/07							
12 GALLONS UNLEADED		6106.435		\$31.00						\$31.00
INVOICE 008573 TOTALS:				\$31.00	\$0.00	\$0.00				\$31.00
008693	03/23/07	04/05/07	05/07/07							
15.6 GALLONS UNLEADED		6106.435		\$34.50						\$34.50
INVOICE 008693 TOTALS:				\$34.50	\$0.00	\$0.00				\$34.50
EUGENE J. PROCELLA, JR. TOTALS:				\$65.50	\$0.00	\$0.00				\$65.50
GAFS GA FOOD SERVICE, INC.										
469629	03/16/07	04/05/07	04/30/07							
2 CASES OVENBRL BEEF PATTY GRAVY		6542.560		\$60.00						\$60.00
2 CASES SWEDISH MEATBALLS NOODLES		6542.560		\$60.00						\$60.00
2 CASES CHOPPED STEAK RANCH GRAVY		6542.560		\$60.00						\$60.00
2 CASES ITALIAN STYLE MEATLOAF		6542.560		\$60.80						\$60.80
2 CASES SALISBURY STEAK W/GRAVY		6542.560		\$60.80						\$60.80
2 CASES SWISS STEAK MUSHROOM GRAVY		6542.560		\$62.00						\$62.00
2 CASES COUNTRY ROAST CHICKEN		6542.560		\$72.00						\$72.00
2 CASES CHICKEN BREAST PATTY		6542.560		\$68.80						\$68.80
2 CASES GRILLED BBQ CHICKEN BREAST		6542.560		\$64.00						\$64.00
4 CASES LEMON PEPPER CHICKEN		6542.560		\$132.00						\$132.00
2 CASES TURKEY BREAST W/DRESSING		6542.560		\$70.00						\$70.00
2 CASES PORK RIBLET W/BBQ SAUCE		6542.560		\$64.00						\$64.00
2 CASES BAKED HAM W/PINEAPPLE		6542.560		\$62.00						\$62.00
2 CASES HAM & BEAN CASSEROLE		6542.560		\$60.00						\$60.00
2 CASES VEAL PARM W/ ITALIAN SAUCE		6542.560		\$60.00						\$60.00
2 CASES SPAGETTI W/ MEAT SAUCE		6542.560		\$60.00						\$60.00
7 CASES HAM & CHEESE SANDWICH		6542.560		\$287.28						\$287.28
7 CASES TURKEY & SWISS SANDWICH		6542.560		\$287.28						\$287.28
7 CASES MEATLOAF SANDWICH		6542.560		\$287.28						\$287.28
7 CASES GRILLED CHICKEN SANDWICH		6542.560		\$287.28						\$287.28

VOL 11 PG 728

\*V - Denotes Voided Check Entries

GENERAL FUND

AP Vendor Detail Ledger (Unpaid Invoices - Payment Detail)

Ledger as of : 4/30/2007

Invoice Number Description	Inv.Date	Trms.Date Account	Due.Date	Amount	Discount	Amount Paid	Check Date	Check Number	Bank	Balance
FREIGHT CHARGES		6542.560		\$266.40						\$266.40
INVOICE 469629 TOTALS:				\$2,491.92	\$0.00	\$0.00				\$2,491.92
GA FOOD SERVICE, INC. TOTALS:				\$2,491.92	\$0.00	\$0.00				\$2,491.92
GALL GALL'S INC.										
5880788000016	03/28/07	04/05/07	05/12/07							
GALLS SEAT ORGANIZER BLACK		6500.560		\$49.99						\$49.99
LEXINGTON		6500.560		\$8.99						\$8.99
INVOICE 5880788000016 TOTALS:				\$58.98	\$0.00	\$0.00				\$58.98
GALL'S INC. TOTALS:				\$58.98	\$0.00	\$0.00				\$58.98
GLPE GLENN PEARSON										
MARCH232007	03/23/07	04/05/07	05/07/07							
JURY COMMISSIONER		6532.435		\$10.00						\$10.00
INVOICE MARCH232007 TOTALS:				\$10.00	\$0.00	\$0.00				\$10.00
GLENN PEARSON TOTALS:				\$10.00	\$0.00	\$0.00				\$10.00
JGCC J.P. COOKE COMPANY										
578458	03/23/07	04/05/07	05/07/07							
N28 CUSTOM XSTAMPER STATE OF TEXAS		6310.403		\$89.95						\$89.95
SHIPPING & HANDLING		6310.403		\$3.30						\$3.30
INVOICE 578458 TOTALS:				\$93.25	\$0.00	\$0.00				\$93.25
J.P. COOKE COMPANY TOTALS:				\$93.25	\$0.00	\$0.00				\$93.25
KCDR K-C DRUGS #2										
45217	03/19/07	04/05/07	05/03/07							
RX 494033		6543.560		\$2.15						\$2.15
RX 494035		6543.560		\$2.15						\$2.15
RX 494032		6543.560		\$2.15						\$2.15
RX 494038		6543.560		\$17.15						\$17.15
INVOICE 45217 TOTALS:				\$23.60	\$0.00	\$0.00				\$23.60
45192	03/26/07	04/05/07	05/10/07							
RX 493972		6543.560		\$24.75						\$24.75

VOL III PG 729

\*V - Denotes Voided Check Entries



**GENERAL FUND**

AP Vendor Detail Ledger (Unpaid Invoices - Payment Detail)

Ledger as of : 4/30/2007

Invoice Number Description	Inv.Date	Trms.Date Account	Due.Date	Amount	Discount	Amount Paid	Check Date	Check Number	Bank	Balance
INVOICE 45192 TOTALS:				\$24.75	\$0.00	\$0.00				\$24.75
K-C DRUGS #2 TOTALS:				\$48.35	\$0.00	\$0.00				\$48.35
<b>LATI LAKEWAY TIRE &amp; SERVICE</b>										
009958	03/26/07	04/05/07	05/10/07							
2 P265/75R16 WRANGLER RTS BW, GOODYEAR		6335.560		\$139.56						\$139.56
INVOICE 009958 TOTALS:				\$139.56	\$0.00	\$0.00				\$139.56
LAKEWAY TIRE & SERVICE TOTALS:				\$139.56	\$0.00	\$0.00				\$139.56
<b>MMCE MMC OF EAST TEXAS</b>										
030707	03/07/07	04/05/07	04/21/07							
LABORATORY		6538.435		\$179.50						\$179.50
EMERGENCY ROOM		6538.435		\$844.25						\$844.25
INVOICE 030707 TOTALS:				\$1,023.75	\$0.00	\$0.00				\$1,023.75
MMC OF EAST TEXAS TOTALS:				\$1,023.75	\$0.00	\$0.00				\$1,023.75
<b>PRIW PREMIER ICE &amp; WATER</b>										
2849	04/01/07	04/05/07	05/16/07							
1 99 RENTAL FEE, 4/1		6310.455		\$10.00						\$10.00
WATER DELIVERY, 5,3/7		6310.455		\$6.45						\$6.45
INVOICE 2849 TOTALS:				\$16.45	\$0.00	\$0.00				\$16.45
2850	04/01/07	04/05/07	05/16/07							
1 WATER DELIVERY 5, 3/6		6310.450		\$6.45						\$6.45
2 WATER DELIVERY 5, 3/27 @ 6.45 EACH		6310.450		\$12.90						\$12.90
INVOICE 2850 TOTALS:				\$19.35	\$0.00	\$0.00				\$19.35
PREMIER ICE & WATER TOTALS:				\$35.80	\$0.00	\$0.00				\$35.80
<b>QUCO QUILL CORPORATION</b>										
5547375	03/21/07	04/05/07	05/05/07							
WIRE DESKTOP FILE ORGANIZER		6310.475		\$6.73						\$6.73
INVOICE 5547375 TOTALS:				\$6.73	\$0.00	\$0.00				\$6.73
5673052	03/26/07	04/05/07	05/10/07							

VOL III PG 730

GENERAL FUND

AP Vendor Detail Ledger (Unpaid Invoices - Payment Detail)

Ledger as of : 4/30/2007

Invoice Number Description	Inv.Date	Trns.Date Account	Due.Date	Amount	Discount	Amount Paid	Check Date	Check Number	Bank	Balance
HP LASER TONER F/SERIES 4 BLACK		6310.450		\$97.99						\$97.99
INVOICE 5673052 TOTALS:				\$97.99	\$0.00	\$0.00				\$97.99
5713477	03/27/07	04/05/07	05/11/07							
HP LJ Q5949A SMART PRINT CTG BLACK		6310.455		\$71.99						\$71.99
INVOICE 5713477 TOTALS:				\$71.99	\$0.00	\$0.00				\$71.99
02916924-1	03/28/07	04/05/07	05/12/07							
QUILL COMP CANNON E20 CPR TNR BLACK		6310.455		\$77.99						\$77.99
INVOICE 02916924-1 TOTALS:				\$77.99	\$0.00	\$0.00				\$77.99
5528109	04/05/07	04/05/07	05/20/07							
PRONG FASTNER BASE 1" CAPACITY		6310.475		\$4.19						\$4.19
FILE FOLDERS W/1/2 CUT TABS		6310.475		\$13.49						\$13.49
QUILL STANDARD STAPLES 5000CT		6310.475		\$1.98						\$1.98
QUILL'S ECONOMY PENCILS #2		6310.475		\$1.09						\$1.09
FREIGHT		6310.475		\$3.94						\$3.94
INVOICE 5528109 TOTALS:				\$24.69	\$0.00	\$0.00				\$24.69
5550165	04/05/07	04/05/07	05/20/07							
5X10" ECONOMY BUBBLE MAILER KRAFT		6310.475		\$11.91						\$11.91
INVOICE 5550165 TOTALS:				\$11.91	\$0.00	\$0.00				\$11.91
QUILL CORPORATION TOTALS:				\$291.30	\$0.00	\$0.00				\$291.30
RECO	RELIABLE OFFICE SUPPLIES									
YX861700	03/12/07	04/05/07	04/26/07							
PWRSHRED STRIP-CUT SHREDDER		6310.457		\$99.99						\$99.99
CANNON D320 PERS COPIER		6310.457		\$299.99						\$299.99
MAXBRITE COPY PAPER		6310.457		\$44.90						\$44.90
TOP NOTCH GRIP MED BLACK PEN		6310.457		\$8.16						\$8.16
HANDLING		6310.457		\$2.76						\$2.76
INVOICE YX861700 TOTALS:				\$455.80	\$0.00	\$0.00				\$455.80
YX861701	03/12/07	04/05/07	04/26/07							
5X8 POLY CARD GUIDES		6310.457		\$17.37						\$17.37
INVOICE YX861701 TOTALS:				\$17.37	\$0.00	\$0.00				\$17.37
YX8641702	03/23/07	04/05/07	05/07/07							

VOL III PG 731

GENERAL FUND

AP Vendor Detail Ledger (Unpaid Invoices - Payment Detail)

Ledger as of : 4/30/2007

Invoice Number Description	Inv.Date	Trns.Date Account	Due.Date	Amount	Discount	Amount Paid	Check Date	Check Number	Bank	Balance
50213 PRINTER CART		6310.457		\$59.99						\$59.99
		INVOICE YX8641702 TOTALS:		\$59.99	\$0.00	\$0.00				\$59.99
		RELIABLE OFFICE SUPPLIES TOTALS:		\$533.16	\$0.00	\$0.00				\$533.16
RITT	RITTER LUMBER CO.									
60116431	03/01/07	04/05/07	04/15/07							
1GALLON HEAVY COVE BASE ASHESIVE		6450.560		\$17.99						\$17.99
LIGHT BULB ACE SOFT 100WT 4PK		6450.560		\$5.96						\$5.96
LIGHT BULB GE FLUORESCENT		6450.560		\$16.47						\$16.47
FS-5 STARTER F/4,6,8 WATT		6450.560		\$3.38						\$3.38
IVORY SWITCH PLATE		6450.560		\$0.49						\$0.49
GALV WIRE ROPE CLIP 1/8"		6450.560		\$0.98						\$0.98
		INVOICE 60116431 TOTALS:		\$45.27	\$0.00	\$0.00				\$45.27
60116531	03/03/07	04/05/07	04/17/07							
3 50# 13-13-13 SHELL BEACH FERTILIZER @ 7.20 EACH		6450.408		\$21.60						\$21.60
		INVOICE 60116531 TOTALS:		\$21.60	\$0.00	\$0.00				\$21.60
060116625	03/05/07	04/05/07	04/19/07							
1 #90 WHITR ROLL ROOFING		6450.560		\$19.95						\$19.95
		INVOICE 060116625 TOTALS:		\$19.95	\$0.00	\$0.00				\$19.95
60116591	03/05/07	04/05/07	04/19/07							
6' PUSHION COAX CABLE		6450.560		\$4.99						\$4.99
		INVOICE 60116591 TOTALS:		\$4.99	\$0.00	\$0.00				\$4.99
60116815	03/08/07	04/05/07	04/22/07							
3 1X12 12 #2 SHELVING		6450.499		\$45.24						\$45.24
1 1X12 8' PONDEROSA PINE		6450.499		\$10.05						\$10.05
2X4 96" YELLOW PINE CORE STUD		6450.499		\$1.98						\$1.98
1X4 8' #2 YELLOW PINE		6450.499		\$3.69						\$3.69
		INVOICE 60116815 TOTALS:		\$60.96	\$0.00	\$0.00				\$60.96
60117684	03/26/07	04/05/07	05/10/07							
OVERNOUT 10LB FIRE ANT KILLER		6450.560		\$19.99						\$19.99
3D MASTER PADLOCK		6450.560		\$8.49						\$8.49
ACE SURGE SUPPRESSOR		6450.560		\$8.49						\$8.49
LONG HANDLE WIRE BRUSH W/SCRAPPER		6450.560		\$3.49						\$3.49

VOL. 11 PG 738

\*V - Denotes Voided Check Entries

GENERAL FUND

AP Vendor Detail Ledger (Unpaid Invoices - Payment Detail)

Ledger as of : 4/30/2007

Invoice Number Description	Inv.Date	Trns.Date Account	Due.Date	Amount	Discount	Amount Paid	Check Date	Check Number	Bank	Balance
SANDPAPER 9X11 GARNET 80 GRIT		6450.560		\$2.67						\$2.67
INVOICE 60117684 TOTALS:				\$43.13	\$0.00	\$0.00				\$43.13
60117685 SPRYKRYLON FLAT BLK 12OZ	03/26/07	04/05/07 6450.560	05/10/07	\$6.98						\$6.98
INVOICE 60117685 TOTALS:				\$6.98	\$0.00	\$0.00				\$6.98
RITTER LUMBER CO. TOTALS:				\$202.88	\$0.00	\$0.00				\$202.88
SCAD SABINE COUNTY APPRAISAL DIST. APRIL,2007	04/05/07	04/05/07 6542.499	05/20/07	\$3,494.50						\$3,494.50
INVOICE APRIL,2007 TOTALS:				\$3,494.50	\$0.00	\$0.00				\$3,494.50
SABINE COUNTY APPRAISAL DIST. TOTALS:				\$3,494.50	\$0.00	\$0.00				\$3,494.50
SCOS SABINE COUNTY SHERIFF DEPT. 030607	03/06/07	04/05/07 6425.560	04/20/07	\$7.19						\$7.19
GEORGE GRIFFITH FOOD ON TRANSFER		6425.560		\$44.17						\$44.17
SHERIFF & TONY FOOD ON TRIP TO AUSTIN		6425.560		\$3.99						\$3.99
GEORGE GRIFFITH FOOD ON TRANSFER		6425.560		\$1.82						\$1.82
TONY MILLER TRIP TO AUSTIN		6425.560		\$2.47						\$2.47
TONY MILLER TRIP TO AUSTIN		6425.560								
INVOICE 030607 TOTALS:				\$59.64	\$0.00	\$0.00				\$59.64
SABINE COUNTY SHERIFF DEPT. TOTALS:				\$59.64	\$0.00	\$0.00				\$59.64
SHSB SHELBY SAVINGS BANK 09570181771	03/19/07	04/05/07 1105.000	05/03/07	\$146.00						\$146.00
ROOM CHARGE		1105.000		\$13.14						\$13.14
CITY OCC TAX		1105.000		\$8.76						\$8.76
STATE OCC TAX		1105.000								
INVOICE 09570181771 TOTALS:				\$167.90	\$0.00	\$0.00				\$167.90
09570181772	03/19/07	04/05/07 1105.000	05/03/07	\$138.00						\$138.00
ROOM CHARGES		1105.000		\$12.42						\$12.42
CITY OCC TAX		1105.000		\$8.28						\$8.28
STATE OCC TAX		1105.000								

VOL TT PG 733

\*V - Denotes Voided Check Entries

GENERAL FUND

AP Vendor Detail Ledger (Unpaid Invoices - Payment Detail)  
Ledger as of : 4/30/2007

Invoice Number Description	Inv.Date	Trms.Date Account	Due.Date	Amount	Discount	Amount Paid	Check Date	Check Number	Bank	Balance
INVOICE 09570181772 TOTALS:				\$158.70	\$0.00	\$0.00				\$158.70
SHELBY SAVINGS BANK TOTALS:				\$326.60	\$0.00	\$0.00				\$326.60
SPLW SPEEDY LUBE, TIRE & MUFFLER										
29622	02/20/07	04/05/07	04/06/07							
OIL & LUBE ON UNIT #5		6335.560		\$34.10						\$34.10
TIRE ROTATION ON UNIT #5		6335.560		\$15.00						\$15.00
INVOICE 29622 TOTALS:				\$49.10	\$0.00	\$0.00				\$49.10
29746	02/24/07	04/05/07	04/10/07							
OIL & LUBE ON SHERIFF'S #10		6450.560		\$34.10						\$34.10
INVOICE 29746 TOTALS:				\$34.10	\$0.00	\$0.00				\$34.10
29774	02/26/07	04/05/07	04/12/07							
OIL & LUBE ON UNIT #7		6335.560		\$34.10						\$34.10
INVOICE 29774 TOTALS:				\$34.10	\$0.00	\$0.00				\$34.10
29790	02/27/07	04/05/07	04/13/07							
OIL & LUBE ON UNIT #3		6335.560		\$29.50						\$29.50
INVOICE 29790 TOTALS:				\$29.50	\$0.00	\$0.00				\$29.50
29830	02/28/07	04/05/07	04/14/07							
OIL&LUBE ON UNIT #6		6335.560		\$34.10						\$34.10
INVOICE 29830 TOTALS:				\$34.10	\$0.00	\$0.00				\$34.10
30035	03/09/07	04/05/07	04/23/07							
2 TIRES ON UNIT #3 @ 12.50 EACH		6335.560		\$25.00						\$25.00
INVOICE 30035 TOTALS:				\$25.00	\$0.00	\$0.00				\$25.00
SPEEDY LUBE, TIRE & MUFFLER TOTALS:				\$205.90	\$0.00	\$0.00				\$205.90
STAC SABINE CO TAX ASSESSOR/COLLECT										
032807	03/28/07	04/05/07	05/12/07							
REFUND JULY'06 TAXES FOR DALTON BORDERS		4000.499		\$28.26						\$28.26
INVOICE 032807 TOTALS:				\$28.26	\$0.00	\$0.00				\$28.26
SABINE CO TAX ASSESSOR/COLLECT TOTALS:				\$28.26	\$0.00	\$0.00				\$28.26

VOL III PG 734

\*V - Denotes Voided Check Entries

**GENERAL FUND**

**AP Vendor Detail Ledger (Unpaid Invoices - Payment Detail)**

Ledger as of : 4/30/2007

Invoice Number Description	Inv.Date	Trns.Date Account	Due.Date	Amount	Discount	Amount Paid	Check Date	Check Number	Bank	Balance
<b>STAP STAPLES, INC.</b>										
7478 25 PK DISKS COLOR IBM	02/21/07	04/05/07 6310.560	04/07/07	\$14.98						\$14.98
INVOICE 7478 TOTALS:				\$14.98	\$0.00	\$0.00				\$14.98
7479 STAPLES 2007 DESKPAD	02/21/07	04/05/07 6310.560	04/07/07	\$7.98						\$7.98
INVOICE 7479 TOTALS:				\$7.98	\$0.00	\$0.00				\$7.98
STAPLES, INC. TOTALS:				\$22.96	\$0.00	\$0.00				\$22.96
<b>STOR STORY-WRIGHT OFFICE SUPPLY</b>										
115911 1PK SEAL 2" DIA GD, 44/PK	03/27/07	04/05/07 6310.450	05/11/07	\$3.89						\$3.89
1DZ TOP97553 LEGAL PADS		6310.450		\$10.95						\$10.95
INVOICE 115911 TOTALS:				\$14.84	\$0.00	\$0.00				\$14.84
115917 3X3 YEL POST IT - HIGHLAND	03/27/07	04/05/07 6310.403	05/11/07	\$4.59						\$4.59
INVOICE 115917 TOTALS:				\$4.59	\$0.00	\$0.00				\$4.59
115911-1 1 DZ PENBK91A ME BLACK PENS	03/28/07	04/05/07 6310.450	05/12/07	\$6.19						\$6.19
INVOICE 115911-1 TOTALS:				\$6.19	\$0.00	\$0.00				\$6.19
STORY-WRIGHT OFFICE SUPPLY TOTALS:				\$25.62	\$0.00	\$0.00				\$25.62
<b>TACO TEXAS ASSOCIATION OF COUNTIES</b>										
102501 2007 TAC ANNUAL CONFERENCE	03/15/07	04/05/07 6470.450	04/29/07	\$225.00						\$225.00
INVOICE 102501 TOTALS:				\$225.00	\$0.00	\$0.00				\$225.00
11893 .2007 TAC ANNUAL CONFERENCE, AUSTIN	04/05/07	04/05/07 6470.403	05/20/07	\$225.00						\$225.00
INVOICE 11893 TOTALS:				\$225.00	\$0.00	\$0.00				\$225.00
192188 2007 TAC ANNUAL CONFERENCE,AUSTIN	04/05/07	04/05/07 6470.497	05/20/07	\$225.00						\$225.00
INVOICE 192188 TOTALS:				\$225.00	\$0.00	\$0.00				\$225.00

VOL III PG 735

GENERAL FUND

AP Vendor Detail Ledger (Unpaid Invoices - Payment Detail)  
Ledger as of : 4/30/2007

Invoice Number Description	Inv.Date	Trns.Date Account	Due.Date	Amount	Discount	Amount Paid	Check Date	Check Number	Bank	Balance
<b>TEXAS ASSOCIATION OF COUNTIES TOTALS:</b>				<b>\$675.00</b>	<b>\$0.00</b>	<b>\$0.00</b>				<b>\$675.00</b>
<b>TPCI TERRILL PETROLEUM CO., INC.</b>										
12405852	03/08/07	04/05/07	04/22/07							
500 GALLONS UNLEADED @ 2.013 PER GAL		6335.560		\$1,006.50						\$1,006.50
500 GALLONS STATE EXCISE TAX @ .20 PER GAL		6335.560		\$100.00						\$100.00
<b>INVOICE 12405852 TOTALS:</b>				<b>\$1,106.50</b>	<b>\$0.00</b>	<b>\$0.00</b>				<b>\$1,106.50</b>
12405887	03/16/07	04/05/07	04/30/07							
400 GALLONS UNLEADED GASOLINE @ 1.976 PER GAL		6335.560		\$790.40						\$790.40
400 GALLONS STATE EXCISE TAX @ .20 PER GAL		6335.560		\$80.00						\$80.00
<b>INVOICE 12405887 TOTALS:</b>				<b>\$870.40</b>	<b>\$0.00</b>	<b>\$0.00</b>				<b>\$870.40</b>
12405955	03/30/07	04/05/07	05/14/07							
400 GALLONS UNLEADED @ 2.047 PER GAL		6335.560		\$818.80						\$818.80
400 GALLONS STATE EXCISE TAX @ .20 PER GAL		6335.560		\$80.00						\$80.00
<b>INVOICE 12405955 TOTALS:</b>				<b>\$898.80</b>	<b>\$0.00</b>	<b>\$0.00</b>				<b>\$898.80</b>
<b>TERRILL PETROLEUM CO., INC. TOTALS:</b>				<b>\$2,875.70</b>	<b>\$0.00</b>	<b>\$0.00</b>				<b>\$2,875.70</b>
<b>WEEL WELDEN ELLIOTT</b>										
MARCH232007	03/23/07	04/05/07	05/07/07							
JURY COMMISSIONER		6532.435		\$10.00						\$10.00
<b>INVOICE MARCH232007 TOTALS:</b>				<b>\$10.00</b>	<b>\$0.00</b>	<b>\$0.00</b>				<b>\$10.00</b>
<b>WELDEN ELLIOTT TOTALS:</b>				<b>\$10.00</b>	<b>\$0.00</b>	<b>\$0.00</b>				<b>\$10.00</b>
<b>WEST WEST PAYMENT CENTER</b>										
813185502	03/30/07	04/05/07	05/14/07							
TX VERN STAT PROPERTY CODE V3		6524.450		\$83.00						\$83.00
TX VERN STAT PROPERTY CODE V4		6524.450		\$83.00						\$83.00
TX VERN STAT PROPERTY CODE V5		6524.450		\$83.00						\$83.00
TX PRACTICE V7 CRIMINAL FORMS & TRIAL MANUAL		6524.450		\$22.50						\$22.50
TX PRACTICE V7A CRIMINAL FORMS & TRIAL MANUAL		6524.450		\$22.50						\$22.50

VOL III PG 736

\*V - Denotes Voided Check Entries

GENERAL FUND

AP Vendor Detail Ledger (Unpaid Invoices - Payment Detail)  
Ledger as of : 4/30/2007

Invoice Number Description	Inv. Date	Trms. Date Account	Due. Date	Amount	Discount	Amount Paid	Check Date	Check Number	Bank	Balance
TX PRACTICE V8 CRIMINAL FORMS & TRIAL MANUAL		6524.450		\$22.50						\$22.50
TX VERNONS ANNO STAT V3 PART 1		6524.450		\$83.00						\$83.00
TX VERNONS ANNO STAT V3 PART 2		6524.450		\$83.00						\$83.00
TX VERNONS ANNO STAT TRANSPORTATION CODE V3		6524.450		\$83.00						\$83.00
TX VERNONS ANNO STAT TRANSPORTATION CODE V3A		6524.450		\$83.00						\$83.00
TX VERNONS ANNO STAT TRANSPORTATION CODE V4		6524.450		\$83.00						\$83.00
INVOICE 813185502 TOTALS:				\$731.50	\$0.00	\$0.00				\$731.50
WEST PAYMENT CENTER TOTALS:				\$731.50	\$0.00	\$0.00				\$731.50
XECC XEROX CORPORATION										
597311643	04/02/07	04/05/07	05/17/07							
430 W/DADF,DUP SERIAL NUMBER UHG-013341		6500.409		\$146.67						\$146.67
INVOICE 597311643 TOTALS:				\$146.67	\$0.00	\$0.00				\$146.67
XEROX CORPORATION TOTALS:				\$146.67	\$0.00	\$0.00				\$146.67
XECH XEROX CORPORATION										
597312445	04/02/07	04/05/07	05/17/07							
420 DIGTL COPIR SERIAL NUMBER NL2-031536		6500.409		\$138.12						\$138.12
INVOICE 597312445 TOTALS:				\$138.12	\$0.00	\$0.00				\$138.12
XEROX CORPORATION TOTALS:				\$138.12	\$0.00	\$0.00				\$138.12
XERX XEROX CORPORATION										
597291914	04/02/07	04/05/07	05/17/07							
CC123 DUPX/DADF SERIAL NUMBER TFW-019263		6500.409		\$115.43						\$115.43
INVOICE 597291914 TOTALS:				\$115.43	\$0.00	\$0.00				\$115.43
597291915	04/02/07	04/05/07	05/17/07							
CC123DUPX/DADF SERIAL NUMBER TFW-019262		6500.409		\$115.43						\$115.43
INVOICE 597291915 TOTALS:				\$115.43	\$0.00	\$0.00				\$115.43
597291916	04/02/07	04/05/07	05/17/07							

VOL. 11 PG 237

\*V - Denotes Voided Check Entries



04/05/07  
3:16:52 PM

GENERAL FUND

AP Vendor Detail Ledger (Unpaid Invoices - Payment Detail)  
Ledger as of : 4/30/2007

Invoice Number Description	Inv.Date	Trms.Date Account	Due.Date	Amount	Discount	Amount Paid	Check Date	Check Number	Bank	Balance
CC123 DUPX/DADF SERIAL NUMBER TFW-019165		6500.409		\$103.88						\$103.88
		INVOICE 597291916 TOTALS:		\$103.88	\$0.00	\$0.00				\$103.88
597291917	04/02/07	04/05/07	05/17/07							
CC123 DUPX/DADF SERIAL NUMBER TFW-019175		6500.409		\$115.45						\$115.45
		INVOICE 597291917 TOTALS:		\$115.45	\$0.00	\$0.00				\$115.45
597291918	04/02/07	04/05/07	05/17/07							
CC123 DUPX/DADF SERIAL NUMBER TFW-019260		6500.409		\$115.43						\$115.43
		INVOICE 597291918 TOTALS:		\$115.43	\$0.00	\$0.00				\$115.43
		XEROX CORPORATION TOTALS:		\$665.62	\$0.00	\$0.00				\$665.62
		LEDGER TOTALS:		\$20,731.47	\$0.00	\$0.00				\$20,731.47

VOL III PG 738

\*V - Denotes Voided Check Entries

SIGN HERE FOR PAYMENT APPROVAL

Charles E. Watson

Charles Watson  
County Judge

SIGN HERE FOR PAYMENT APPROVAL

Keith Clark

Keith Clark  
Commissioner Pct. 1

SIGN HERE FOR PAYMENT APPROVAL

Doyle Dickerson

Doyle Dickerson  
Commissioner Pct. 3

SIGN HERE FOR PAYMENT APPROVAL

Janice McDaniel

Janice McDaniel  
County Clerk

SIGN HERE FOR PAYMENT APPROVAL

Jimmy McDaniel

Jimmy McDaniel  
Commissioner Pct. 2

SIGN HERE FOR PAYMENT APPROVAL

Fayne Warner

Fayne Warner  
Commissioner Pct. 4

VOL III PG 139

Approved for payment by Sabine County Commissioner's Court on April 09, 2007

**ROAD AND BRIDGES**

**AP Vendor Detail Ledger (Unpaid Invoices - Payment Detail)**  
**Ledger as of : 4/30/2007**

Invoice Number Description	Inv.Date	Trns.Date Account	Due.Date	Amount	Discount	Amount Paid	Check Date	Check Number	Bank	Balance
<b>ACLL ATTOYAC CONSTRUCTION, LLC</b>										
126 384.27 TONS OF ROAD BASE	03/28/07	04/05/07 6377.603	03/28/07	\$2,497.80						\$2,497.80
INVOICE 126 TOTALS:				\$2,497.80	\$0.00	\$0.00				\$2,497.80
ATTOYAC CONSTRUCTION, LLC TOTALS:				\$2,497.80	\$0.00	\$0.00				\$2,497.80
<b>BIG4 BIG "4", INC.</b>										
00330034 12 YARDS OF ROAD BASE	03/05/07	04/05/07 6377.601	03/05/07	\$108.00						\$108.00
INVOICE 00330034 TOTALS:				\$108.00	\$0.00	\$0.00				\$108.00
00330039 196 YARDS OF ROAD BASE	03/05/07	04/05/07 6377.603	03/05/07	\$1,764.00						\$1,764.00
INVOICE 00330039 TOTALS:				\$1,764.00	\$0.00	\$0.00				\$1,764.00
00330121 24 YARDS OF ROAD BASE	03/08/07	04/05/07 6377.604	03/08/07	\$144.00						\$144.00
INVOICE 00330121 TOTALS:				\$144.00	\$0.00	\$0.00				\$144.00
00330111 60 YARDS OF ROAD BASE	03/21/07	04/05/07 6377.601	03/21/07	\$540.00						\$540.00
INVOICE 00330111 TOTALS:				\$540.00	\$0.00	\$0.00				\$540.00
00330113 39 YARDS OF ROAD BASE	03/21/07	04/05/07 6377.602	03/21/07	\$351.00						\$351.00
INVOICE 00330113 TOTALS:				\$351.00	\$0.00	\$0.00				\$351.00
00330116 252 YARDS OF ROAD BASE	03/21/07	04/05/07 6377.603	03/21/07	\$2,268.00						\$2,268.00
INVOICE 00330116 TOTALS:				\$2,268.00	\$0.00	\$0.00				\$2,268.00
00330119 52 YARDS OF ROAD BASE	03/21/07	04/05/07 6377.602	03/21/07	\$468.00						\$468.00
INVOICE 00330119 TOTALS:				\$468.00	\$0.00	\$0.00				\$468.00
00330140 12 YARDS OF ROAD BASE	03/28/07	04/05/07 6377.603	03/28/07	\$72.00						\$72.00
INVOICE 00330140 TOTALS:				\$72.00	\$0.00	\$0.00				\$72.00

VOL III PG 740

\*V - Denotes Voided Check Entries

04/05/07  
1:49:30 PM

**ROAD AND BRIDGES**

**AP Vendor Detail Ledger (Unpaid Invoices - Payment Detail)**

Ledger as of : 4/30/2007

Invoice Number Description	Inv.Date	Trms.Date Account	Due.Date	Amount	Discount	Amount Paid	Check Date	Check Number	Bank	Balance
00330144 48 YARDS OF ROAD BASE	03/26/07	04/05/07 6377.604	03/26/07	\$312.00						\$312.00
INVOICE 00330144 TOTALS:				\$312.00	\$0.00	\$0.00				\$312.00
00330112 84 YARDS OF ROAD BASE	04/05/07	04/05/07 6377.604	04/05/07	\$756.00						\$756.00
INVOICE 00330112 TOTALS:				\$756.00	\$0.00	\$0.00				\$756.00
00330118 168 YARDS OF ROAD BASE	04/05/07	04/05/07 6377.601	04/05/07	\$1,512.00						\$1,512.00
INVOICE 00330118 TOTALS:				\$1,512.00	\$0.00	\$0.00				\$1,512.00
BIG "4", INC. TOTALS:				\$8,295.00	\$0.00	\$0.00				\$8,295.00
CING 766987402X03252007 DOYLE DICKERSON CELL PHONE BILL	04/05/07	04/05/07 6420.603	04/05/07	\$69.63						\$69.63
INVOICE 766987402X03252007 TOTALS:				\$69.63	\$0.00	\$0.00				\$69.63
CINGULAR WIRELESS TOTALS:				\$69.63	\$0.00	\$0.00				\$69.63
CITY 040507 ACCT# 10-0010-01 UTILITIES	04/05/07	04/05/07 6440.601	04/05/07	\$219.54						\$219.54
INVOICE 040507 TOTALS:				\$219.54	\$0.00	\$0.00				\$219.54
CITY OF HEMPHILL TOTALS:				\$219.54	\$0.00	\$0.00				\$219.54
CIWI 343738836X03262007 CELL PHONE BILL	04/05/07	04/05/07 6420.601	04/05/07	\$101.21						\$101.21
INVOICE 343738836X03262007 TOTALS:				\$101.21	\$0.00	\$0.00				\$101.21
CINGULAR WIRELESS TOTALS:				\$101.21	\$0.00	\$0.00				\$101.21
GCWM 040507 RONALD TONEY HYPERTENSION NOS	04/05/07	04/05/07 6651.601	04/05/07	\$95.00						\$95.00

VOL III PG 741

\*V - Denotes Voided Check Entries

04/05/07  
1:49:30 PM

**ROAD AND BRIDGES**

**AP Vendor Detail Ledger (Unpaid Invoices - Payment Detail)**  
**Ledger as of : 4/30/2007**

Invoice Number Description	Inv.Date	Trms.Date Account	Due.Date	Amount	Discount	Amount Paid	Check Date	Check Number	Bank	Balance
INVOICE 040507 TOTALS:				\$95.00	\$0.00	\$0.00				\$95.00
GROVER C. WINSLOW, M.D. TOTALS:				\$95.00	\$0.00	\$0.00				\$95.00
GMWS	G-M WATER SUPPLY CORP.									
040507	04/05/07	04/05/07	04/05/07							
PCT#4 WATER BILL ACCT# 2251		6440.604		\$31.66						\$31.66
INVOICE 040507 TOTALS:				\$31.66	\$0.00	\$0.00				\$31.66
G-M WATER SUPPLY CORP. TOTALS:				\$31.66	\$0.00	\$0.00				\$31.66
GRAY	GRAY'S WHOLESALE TIRE									
965807	03/26/07	04/05/07	03/26/07							
4 LT265/70R17 TIRES @ 95.70 EACH		6365.602		\$382.80						\$382.80
INVOICE 965807 TOTALS:				\$382.80	\$0.00	\$0.00				\$382.80
GRAY'S WHOLESALE TIRE TOTALS:				\$382.80	\$0.00	\$0.00				\$382.80
JAAS	JASPER ASPHALT LIMITED									
2156	03/30/07	04/05/07	03/30/07							
206.99 TONS OF OIL SAND BASE		6378.602		\$9,211.06						\$9,211.06
INVOICE 2156 TOTALS:				\$9,211.06	\$0.00	\$0.00				\$9,211.06
JASPER ASPHALT LIMITED TOTALS:				\$9,211.06	\$0.00	\$0.00				\$9,211.06
JTGR	J.T. GREENE TRUCK & EQUIPMENT									
4652	03/30/07	04/05/07	03/30/07							
1/2 HOUR OF LABOR		6344.604		\$25.00						\$25.00
INVOICE 4652 TOTALS:				\$25.00	\$0.00	\$0.00				\$25.00
4459	04/02/07	04/05/07	04/02/07							
1 HOUR OF LABOR		6345.604		\$50.00						\$50.00
INVOICE 4459 TOTALS:				\$50.00	\$0.00	\$0.00				\$50.00
J.T. GREENE TRUCK & EQUIPMENT TOTALS:				\$75.00	\$0.00	\$0.00				\$75.00
LETC	LETCO - GROUP									
9230953-IN	03/20/07	04/05/07	03/20/07							

VOL III PG 742

\*V - Denotes Voided Check Entries

04/05/07  
1:49:30 PM

**ROAD AND BRIDGES**

**AP Vendor Detail Ledger (Unpaid Invoices - Payment Detail)**

Ledger as of : 4/30/2007

Invoice Number Description	Inv.Date	Trms.Date Account	Due.Date	Amount	Discount	Amount Paid	Check Date	Check Number	Bank	Balance
20.51 TONS OF ROAD BASE		6377.601		\$358.93						\$358.93
INVOICE 9230953-IN TOTALS:				\$358.93	\$0.00	\$0.00				\$358.93
9230977-IN 19.72 TONS OF ROAD BASE	03/20/07	04/05/07 6377.601	03/20/07	\$345.10						\$345.10
INVOICE 9230977-IN TOTALS:				\$345.10	\$0.00	\$0.00				\$345.10
9238660-IN ROAD BASE 21.08 TONS	03/26/07	04/05/07 6377.604	03/26/07	\$368.90						\$368.90
INVOICE 9238660-IN TOTALS:				\$368.90	\$0.00	\$0.00				\$368.90
9238747-IN ROAD BASE 20.93 TONS	03/26/07	04/05/07 6377.604	03/26/07	\$366.28						\$366.28
INVOICE 9238747-IN TOTALS:				\$366.28	\$0.00	\$0.00				\$366.28
LETCO - GROUP TOTALS:				\$1,439.21	\$0.00	\$0.00				\$1,439.21
MSRO M & S ROCK 07-1059	04/01/07	04/05/07 6377.604	04/01/07	\$1,917.96						\$1,917.96
INVOICE 07-1059 TOTALS:				\$1,917.96	\$0.00	\$0.00				\$1,917.96
M & S ROCK TOTALS:				\$1,917.96	\$0.00	\$0.00				\$1,917.96
NAPAS NAPA TOLEDO AUTOMOTIVE 573523	03/15/07	04/05/07	03/15/07							
1 TEMINAL		6657.604		\$3.49						\$3.49
1 TAPE		6657.604		\$5.99						\$5.99
1 BIT		6657.604		\$1.99						\$1.99
6 SCREWS		6657.604		\$1.75						\$1.75
INVOICE 573523 TOTALS:				\$13.22	\$0.00	\$0.00				\$13.22
NAPA TOLEDO AUTOMOTIVE TOTALS:				\$13.22	\$0.00	\$0.00				\$13.22
NAPH NAPA AUTO PARTS- HEMPHILL 358997	03/09/07	04/05/07	03/09/07							
1 FUEL FILTER		6657.604		\$16.66						\$16.66
INVOICE 358997 TOTALS:				\$16.66	\$0.00	\$0.00				\$16.66

VOL III PG 743

\*V - Denotes Voided Check Entries

04/05/07  
1:49:30 PM

**ROAD AND BRIDGES**

AP Vendor Detail Ledger (Unpaid Invoices - Payment Detail)

Ledger as of : 4/30/2007

Invoice Number Description	Inv.Date	Trns.Date Account	Due.Date	Amount	Discount	Amount Paid	Check Date	Check Number	Bank	Balance
<b>359364</b>	<b>03/15/07</b>	<b>04/05/07</b>	<b>03/15/07</b>							
3 SCREW DRIVERS		6657.604		\$5.97						\$5.97
2 TERMINAL		6657.604		\$4.58						\$4.58
		INVOICE 359364 TOTALS:		\$10.55	\$0.00	\$0.00				\$10.55
<b>359370</b>	<b>03/15/07</b>	<b>04/05/07</b>	<b>03/15/07</b>							
1 TEST INS		6657.604		\$6.19						\$6.19
		INVOICE 359370 TOTALS:		\$6.19	\$0.00	\$0.00				\$6.19
<b>359812</b>	<b>03/22/07</b>	<b>04/05/07</b>	<b>03/22/07</b>							
1 LUG WRENCH		6657.602		\$14.59						\$14.59
		INVOICE 359812 TOTALS:		\$14.59	\$0.00	\$0.00				\$14.59
<b>359884</b>	<b>03/23/07</b>	<b>04/05/07</b>	<b>03/23/07</b>							
1 ANTIFREEZE		6342.604		\$11.99						\$11.99
		INVOICE 359884 TOTALS:		\$11.99	\$0.00	\$0.00				\$11.99
		<b>NAPA AUTO PARTS - HEMPHILL TOTALS:</b>		<b>\$59.98</b>	<b>\$0.00</b>	<b>\$0.00</b>				<b>\$59.98</b>
<b>RILU</b>	<b>RITTER LUMBER CO.</b>									
<b>060116769</b>	<b>03/08/07</b>	<b>04/05/07</b>	<b>03/08/07</b>							
1 BAR AND CHAIN OIL		6657.602		\$5.99						\$5.99
1 GAS CAN AUTO SHUTOFF		6657.602		\$8.49						\$8.49
2 2-CYCLE OIL		6343.602		\$1.98						\$1.98
		INVOICE 060116769 TOTALS:		\$16.46	\$0.00	\$0.00				\$16.46
<b>060116993</b>	<b>03/12/07</b>	<b>04/05/07</b>	<b>03/12/07</b>							
1 CHAINSAW FILE		6657.602		\$4.99						\$4.99
1 CHAINSAW FILE WITH GUIDE		6657.602		\$7.99						\$7.99
1 GMOUNT CHOK/CARB CLEAN		6657.602		\$3.29						\$3.29
2 ROPE NYLON		6657.602		\$0.38						\$0.38
		INVOICE 060116993 TOTALS:		\$16.65	\$0.00	\$0.00				\$16.65
<b>060117783</b>	<b>03/28/07</b>	<b>04/05/07</b>	<b>03/28/07</b>							
1 MID WEST GAS CAN		6657.602		\$11.49						\$11.49
1 TRI PROXY SPRAYER		6657.602		\$38.99						\$38.99
		INVOICE 060117783 TOTALS:		\$50.48	\$0.00	\$0.00				\$50.48
<b>060116749</b>	<b>04/05/07</b>	<b>04/05/07</b>	<b>04/05/07</b>							
1 8" WINDOW BRUSH		6657.601		\$6.49						\$6.49

VOL ITT PG 744

\*V - Denotes Voided Check Entries

**ROAD AND BRIDGES**

AP Vendor Detail Ledger (Unpaid Invoices - Payment Detail)

Ledger as of : 4/30/2007

Invoice Number Description	Inv.Date	Trns.Date Account	Due.Date	Amount	Discount	Amount Paid	Check Date	Check Number	Bank	Balance
INVOICE 060116749 TOTALS:				\$6.49	\$0.00	\$0.00				\$6.49
060117542 2 LIGHT BULB ACE FLOURESCENT	04/05/07	04/05/07 6657.601	04/05/07	\$3.98						\$3.98
INVOICE 060117542 TOTALS:				\$3.98	\$0.00	\$0.00				\$3.98
RITTER LUMBER CO. TOTALS:				\$94.06	\$0.00	\$0.00				\$94.06
TACO TEXAS ASSOCIATION OF COUNTIES										
040507 PCT#2 ANNUAL TAC CONFERENCE	04/05/07	04/05/07 6654.602	04/05/07	\$225.00						\$225.00
INVOICE 040507 TOTALS:				\$225.00	\$0.00	\$0.00				\$225.00
TEXAS ASSOCIATION OF COUNTIES TOTALS:				\$225.00	\$0.00	\$0.00				\$225.00
TPCI TERRILL PETROLEUM										
66166 19 GALLONS OF SUPER UNLEADED	03/02/07	04/05/07 6335.603	03/02/07	\$41.18						\$41.18
EXCISE TAX		6335.603		\$3.80						\$3.80
INVOICE 66166 TOTALS:				\$44.98	\$0.00	\$0.00				\$44.98
66168 20.68 GALLONS OF UNLEADED	03/05/07	04/05/07 6335.602	03/05/07	\$41.09						\$41.09
EXCISE TAX		6335.602		\$4.14						\$4.14
INVOICE 66168 TOTALS:				\$45.23	\$0.00	\$0.00				\$45.23
66171 12.7 GALLONS OF UNLEADED	03/08/07	04/05/07 6335.603	03/08/07	\$25.23						\$25.23
EXCISE TAX		6335.603		\$2.54						\$2.54
INVOICE 66171 TOTALS:				\$27.77	\$0.00	\$0.00				\$27.77
66177 .89 GALLONS OF UNLEADED	03/08/07	04/05/07 6335.602	03/08/07	\$1.78						\$1.78
EXCISE TAX		6335.602		\$0.18						\$0.18
INVOICE 66177 TOTALS:				\$1.96	\$0.00	\$0.00				\$1.96
66185 22.03 GALLONS OF UNLEADED	03/14/07	04/05/07 6335.603	03/14/07	\$43.54						\$43.54
EXCISE TAX		6335.603		\$4.41						\$4.41

VOL TIT 745 PG 6

\*V - Denotes Voided Check Entries



ROAD AND BRIDGES

AP Vendor Detail Ledger (Unpaid Invoices - Payment Detail)

Ledger as of : 4/30/2007

Invoice Number Description	Inv.Date	Trns.Date Account	Due.Date	Amount	Discount	Amount Paid	Check Date	Check Number	Bank	Balance
INVOICE 66185 TOTALS:				\$47.95	\$0.00	\$0.00				\$47.95
12405879	03/15/07	04/05/07	03/15/07							
800 GALLONS OF DIESEL		6336.603		\$1,728.80						\$1,728.80
EXCISE TAX		6336.603		\$160.00						\$160.00
INVOICE 12405879 TOTALS:				\$1,888.80	\$0.00	\$0.00				\$1,888.80
66191	03/20/07	04/05/07	03/20/07							
22.63 GALLONS OF UNLEADED		6335.603		\$45.17						\$45.17
EXCISE TAX		6335.603		\$4.53						\$4.53
INVOICE 66191 TOTALS:				\$49.70	\$0.00	\$0.00				\$49.70
12405902	03/21/07	04/05/07	03/21/07							
450 GALLONS OF UNLEADED		6335.604		\$898.20						\$898.20
EXCISE TAX		6335.604		\$90.00						\$90.00
445 GALLONS OF DIESEL		6336.604		\$938.06						\$938.06
EXCISE TAX		6336.604		\$89.00						\$89.00
INVOICE 12405902 TOTALS:				\$2,015.26	\$0.00	\$0.00				\$2,015.26
66197	03/22/07	04/05/07	03/22/07							
12.93 GALLONS OF UNLEADED		6335.603		\$25.84						\$25.84
EXCISE TAX		6335.603		\$2.56						\$2.56
INVOICE 66197 TOTALS:				\$28.40	\$0.00	\$0.00				\$28.40
66202	03/26/07	04/05/07	03/26/07							
17.83 GALLONS OF UNLEADED		6335.603		\$36.05						\$36.05
EXCISE TAX		6335.603		\$3.57						\$3.57
INVOICE 66202 TOTALS:				\$39.62	\$0.00	\$0.00				\$39.62
12405839	03/29/07	04/05/07	03/29/07							
450 GALLONS OF UNLEADED		6335.601		\$908.55						\$908.55
EXCISE TAX		6335.601		\$90.00						\$90.00
750 GALLONS OF DIESEL		6336.601		\$1,616.25						\$1,616.25
EXCISE TAX		6336.601		\$150.00						\$150.00
INVOICE 12405839 TOTALS:				\$2,764.80	\$0.00	\$0.00				\$2,764.80
12405876	04/05/07	04/05/07	04/05/07							
1000 GALLONS OF DIESEL		6336.602		\$2,161.00						\$2,161.00
EXCISE TAX		6336.602		\$200.00						\$200.00
INVOICE 12405876 TOTALS:				\$2,361.00	\$0.00	\$0.00				\$2,361.00

VOL TFI PG 746

\*V - Denotes Voided Check Entries

04/05/07  
1:49:30 PM

**ROAD AND BRIDGES**

**AP Vendor Detail Ledger (Unpaid Invoices - Payment Detail)**

Ledger as of : 4/30/2007

Invoice Number Description	Inv.Date	Trns.Date Account	Due.Date	Amount	Discount	Amount Paid	Check Date	Check Number	Bank	Balance
<b>66179</b>	<b>04/05/07</b>	<b>04/05/07</b>	<b>04/05/07</b>							
13.31 GALLONS OF SUPER		6335.603		\$28.87						\$28.87
EXCISE TAX		6335.603		\$2.67						\$2.67
INVOICE 66179 TOTALS:				\$31.54	\$0.00	\$0.00				\$31.54
<b>66181</b>	<b>04/05/07</b>	<b>04/05/07</b>	<b>04/05/07</b>							
17.78 GALLONS OF UNLEADED		6335.602		\$34.55						\$34.55
EXCISE TAX		6335.602		\$3.56						\$3.56
INVOICE 66181 TOTALS:				\$38.11	\$0.00	\$0.00				\$38.11
<b>66188</b>	<b>04/05/07</b>	<b>04/05/07</b>	<b>04/05/07</b>							
19.67 GALLONS OF UNLEADED		6335.602		\$38.87						\$38.87
EXCISE TAX		6335.602		\$3.93						\$3.93
INVOICE 66188 TOTALS:				\$42.80	\$0.00	\$0.00				\$42.80
<b>66204</b>	<b>04/05/07</b>	<b>04/05/07</b>	<b>04/05/07</b>							
20.96 GALLONS OF UNLEADED		6335.602		\$42.91						\$42.91
EXCISE TAX		6335.602		\$3.86						\$3.86
INVOICE 66204 TOTALS:				\$46.77	\$0.00	\$0.00				\$46.77
TERRILL PETROLEUM TOTALS:				\$9,474.69	\$0.00	\$0.00				\$9,474.69
LEDGER TOTALS:				\$34,292.82	\$0.00	\$0.00				\$34,292.82

VOL III PG 747

\*V - Denotes Voided Check Entries

SIGN HERE FOR PAYMENT APPROVAL

Charles E. Watson

Charles Watson  
County Judge

SIGN HERE FOR PAYMENT APPROVAL

Janice McDaniel

Janice McDaniel  
County Clerk

VOL. I PG 748

SIGN HERE FOR PAYMENT APPROVAL

Keith Clark

Keith Clark  
Commissioner Pct. 1

SIGN HERE FOR PAYMENT APPROVAL

Jimmy McDaniel

Jimmy McDaniel  
Commissioner Pct. 2

SIGN HERE FOR PAYMENT APPROVAL

Doyle Dickerson

Doyle Dickerson  
Commissioner Pct. 3

SIGN HERE FOR PAYMENT APPROVAL

Fayne Warner

Fayne Warner  
Commissioner Pct. 4

Approved for payment by Sabine County Commissioner's Court on April 09, 2007

04/05/07

1:51:13 PM

ROAD AND BRIDGE SPECIAL

AP Vendor Detail Ledger (Unpaid Invoices - Payment Detail)

Ledger as of : 4/30/2007

Invoice Number Description	Inv.Date	Trns.Date Account	Due.Date	Amount	Discount	Amount Paid	Check Date	Check Number	Bank	Balance
LANE LANE'S										
040507	04/05/07	04/05/07	04/05/07							
BALANCE DUE		6355.6050		\$9.44						\$9.44
INVOICE 040507 TOTALS:				\$9.44	\$0.00	\$0.00				\$9.44
LANE'S TOTALS:				\$9.44	\$0.00	\$0.00				\$9.44
LEDGER TOTALS:				\$9.44	\$0.00	\$0.00				\$9.44

VOL TT PG 749

SIGN HERE FOR PAYMENT APPROVAL

Charles E. Watson

Charles Watson  
County Judge

SIGN HERE FOR PAYMENT APPROVAL

Janice McDaniel

Janice McDaniel  
County Clerk

VOL III PG 750

SIGN HERE FOR PAYMENT APPROVAL

Keith Clark

Keith Clark  
Commissioner Pct. 1

SIGN HERE FOR PAYMENT APPROVAL

Jimmy McDaniel

Jimmy McDaniel  
Commissioner Pct. 2

SIGN HERE FOR PAYMENT APPROVAL

Doyle Dickerson

Doyle Dickerson  
Commissioner Pct. 3

SIGN HERE FOR PAYMENT APPROVAL

Fayne Warner

Fayne Warner  
Commissioner Pct. 4

Approved for payment by Sabine County Commissioner's Court on April 09, 2007

04/05/07

3:32:46 PM

SABINE COUNTY FSM/SPECIAL PROJECTS

AP Vendor Detail Ledger (Unpaid Invoices - Payment Detail)

Ledger as of : 4/30/2007

Invoice Number Description	Inv.Date	Trns.Date Account	Due.Date	Amount	Discount	Amount Paid	Check Date	Check Number	Bank	Balance
<b>CAWE C CAMPBELL</b>										
030207 WATER TANK FOR FIRE TRUCK HEMPHILL VFD	03/02/07	04/05/07 6502.225	03/02/07	\$3,205.59						\$3,205.59
INVOICE 030207 TOTALS:				\$3,205.59	\$0.00	\$0.00				\$3,205.59
C CAMPBELL TOTALS:				\$3,205.59	\$0.00	\$0.00				\$3,205.59
<b>FBAT FIRST BANK AND TRUST</b>										
MARCH29,2007 AMOUNT TO BE APPLIED TO NOTE #583370	03/29/07	04/05/07 6507.225	03/29/07	\$2,786.89						\$2,786.89
INVOICE MARCH29,2007 TOTALS:				\$2,786.89	\$0.00	\$0.00				\$2,786.89
FIRST BANK AND TRUST TOTALS:				\$2,786.89	\$0.00	\$0.00				\$2,786.89
<b>SACC SABINE AREA CAREER CENTER</b>										
032607 FUNDS BUDGETED TO SABINE AREA CAREER CENTER	03/26/07	04/05/07 6468.225	03/26/07	\$15,000.00						\$15,000.00
INVOICE 032607 TOTALS:				\$15,000.00	\$0.00	\$0.00				\$15,000.00
SABINE AREA CAREER CENTER TOTALS:				\$15,000.00	\$0.00	\$0.00				\$15,000.00
LEDGER TOTALS:				\$20,992.48	\$0.00	\$0.00				\$20,992.48

VOL ITT PG 751

SIGN HERE FOR PAYMENT APPROVAL

Charles E. Watson

Charles Watson  
County Judge

SIGN HERE FOR PAYMENT APPROVAL

Janice McDaniel

Janice McDaniel  
County Clerk

VOL. 111 PG. 158

SIGN HERE FOR PAYMENT APPROVAL

Keith Clark

Keith Clark  
Commissioner Pct. 1

SIGN HERE FOR PAYMENT APPROVAL

Jimmy McDaniel

Jimmy McDaniel  
Commissioner Pct. 2

SIGN HERE FOR PAYMENT APPROVAL

Doyle Dickerson

Doyle Dickerson  
Commissioner Pct. 3

SIGN HERE FOR PAYMENT APPROVAL

Fayne Warner

Fayne Warner  
Commissioner Pct. 4

Approved for payment by Sabine County Commissioner's Court on April 09, 2007

EXTENSION ACTIVITY REPORT TO COUNTY COMMISSIONERS COURTS

Miles Traveled: 464

Selected Activities Since Last Report:

- 5 - completed 2006 performance appraisal
- 6 - attended monthly Busy Bees TEEA meeting
- 7 - presented "Nutrition Quackery" at the East Sebaste Senior Nutrition Center
- 7 - issued student protest for the Balance Your Day with Food and Play Pilot program at Hemphill Elementary
- 8 - participated in a community child safety seat checkup event in Newton county
- 9 - wrote newspaper article "Questions and Answers: Medical Professionals"
- 12 - presented program on Balance Your Day with Food and Play at Hemphill Elementary
- 13 - presented program on Balance Your Day with Food and Play at Hemphill Elementary
- 13 - presented Nutrition Quiz Bowl update for participants
- 15 - presented program on Balance Your Day with Food and Play at Hemphill Elementary
- 15 - presented "Dress to Impress" at West Sebaste's Career Day
- 16 - presented program on Balance Your Day with Food and Play at Hemphill Elementary
- 16 - 3 safety seat appointments
- 16 - wrote newspaper article "Seven Steps to a Healthy Home"
- 17 - participated in Pratt House Civil War Reenactment with the Busy Bees TEEA Club
- 19 - presented program on Balance Your Day with Food and Play at Hemphill Elementary
- 19 - attended monthly 4-H meeting
- 20 - presented program on Balance Your Day with Food and Play at Hemphill Elementary
- 20 - presented Busy Bees TEEA Club's cultural arts activity
- 20 - one safety seat appointment
- 21 - participated in a Centra update on the Balance Your Day with Food and Play program
- 22 - presented program on Balance Your Day with Food and Play at Hemphill Elementary
- 23 - presented program on Balance Your Day with Food and Play at Hemphill Elementary
- 23 - wrote newspaper article "Brown Rice: Just as Good the Second Time Around"
- 23 - 3 safety seat appointments
- 26 - presented quarterly TEAFCS Agents' meeting in Hemphill
- 27 - presented program on Balance Your Day with Food and Play at Hemphill Elementary
- 29 - presented program on Balance Your Day with Food and Play at Hemphill Elementary
- 30 - presented program on Balance Your Day with Food and Play at Hemphill Elementary
- 30 - one safety seat appointment

Mileage taken for next month:

- 2 - present high school financial management program at West Sebaste and Brookland High Schools
- 2 - complete Balance Your Day with Food and Play pilot program at Hemphill Elementary
- 3 - present "Tension Teasers" to the Busy Bees TEEA Club for their monthly meeting
- 7 - participate in the foods division of the Junior Livestock Show
- 9 - present high school financial management at Brookland High School
- 12 - present senior nutrition program at the East Sebaste Senior Nutrition Center
- 14 - participate in the District 5 4-H Fashion Show
- 16 - present high school financial management program at West Sebaste and Brookland High School
- 16 - attend 4-H monthly meeting
- 23 - present high school financial management program at West Sebaste High School
- 25 - judge Newton County home economics division at their county fair
- 28 - participate in district 5 4-H roundup
- 30 - present high school financial management programs at West Sebaste and Brookland High Schools

Name: Armeda Dyeann

County: Sebaste

Title: County Extension Agent - Family & Consumer Sciences

Date: March, 2007

VOL TT pg 753



**TEXAS COOPERATIVE EXTENSION**  
 The Texas A&M University System  
**MONTHLY SCHEDULE OF TRAVEL**

Name: Amanda Drennan

Title: County Extension Agent - FCS

County: Sabine

Month: March

Date	Activity	Miles Traveled	Meals	Lodging
6	First United Methodist Church	2		
7	East Sabine Senior Nutrition Center	2		
7	Hemphill Elementary	2		
8	Newton County Extension Office	90		
12	Hemphill Elementary	2		
13	Hemphill Elementary	2		
15	Hemphill Elementary	2		
15	Sabine Career Center (2 roundtrips)	48		
16	Hemphill Elementary	2		
16	West Sabine High School	24		
17	Pratt House	2		
18	Jasper for Program Supplies	72		
19	Hemphill Elementary	2		
19	Youth Foundation Building	6		
20	First United Methodist Church	2		
20	Hemphill Elementary	2		
21	Nacogdoches for program supplies	124		
22	Hemphill Elementary	2		
23	Hemphill Elementary	2		
26	First United Methodist Church	2		
27	Hemphill Elementary	2		
29	Hemphill Elementary	2		
29	Jasper County Extension Office	72		
30	Hemphill Elementary	2		
	<b>Total</b>	<b>464</b>		

VOL TT PG 754

I hereby certify this is a true and correct report of travel (mileage) and other expenses incurred by me in the performance of my official duties for the month shown.

Date: 4-3-07

Signed: Amanda Drennan

**MARTHA M. STONE**  
**SABINE COUNTY TAX ASSESSOR/COLLECTOR**  
**P.O. BOX 310 HEMPHILL, TX. 75948**  
**(409) 787-2257 FAX (409) 787-4753**

**Sabine County**  
**Tax Collections for March 2007**

<b>2006 Levy:</b>	<b>\$1,431,847.44</b>
<b>Collections:</b>	
Current	
Current Delinquent	21831.94
Current Delinquent P&I	1893.33
Delinquent	3946.50
Penalty & Interest	2019.48

**TOTAL: \$ 29691.25**

Percentage of 2006 taxes collected: 90.86%  
Current taxes due as of March 01, 2006: \$ 130910.96  
Delinquent taxes (2005 & prior years) as of March 1, 2006: \$183013.79  
Old State taxes due as of December 1, 2006: \$ 77.21

I hereby certify with my official seal of office that the above figures are true and correct records of collections made through the Sabine County Tax Office.

Martha Stone  
Martha M. Stone  
Sabine County Tax A/C

April 2007

VOL IT PG 755

01 COUNTY

Yearly Beg Bal	Beg Bal	Total Due	Collected					Total Paid	% Collected	
			Base Tax	Discount	Penalty	Attmry Fee	Other Payment			
1967	0.00	0.00	0.00	0.00	0.00	0.00	0.00	0.00	0.00%	
1968	0.00	0.00	0.00	0.00	0.00	0.00	0.00	0.00	0.00%	
1969	0.00	0.00	0.00	0.00	0.00	0.00	0.00	0.00	0.00%	
1970	0.00	0.00	0.00	0.00	0.00	0.00	0.00	0.00	0.00%	
1971	0.00	0.00	0.00	0.00	0.00	0.00	0.00	0.00	0.00%	
1972	0.00	0.00	0.00	0.00	0.00	0.00	0.00	0.00	0.00%	
1973	0.00	0.00	0.00	0.00	0.00	0.00	0.00	0.00	0.00%	
1974	0.00	0.00	0.00	0.00	0.00	0.00	0.00	0.00	0.00%	
1975	3.20	3.20	3.20	0.00	0.00	0.00	0.00	0.00	0.00%	
1976	5.20	5.20	5.20	0.00	0.00	0.00	0.00	0.00	0.00%	
1977	105.00	105.00	105.00	0.00	0.00	0.00	0.00	0.00	0.00%	
1978	240.39	240.39	221.35	0.00	0.00	0.00	0.00	0.00	7.92%	
1979	283.28	283.28	260.24	0.00	0.00	0.00	0.00	0.00	8.13%	
1980	420.78	416.78	386.22	0.00	0.00	0.00	0.00	0.00	8.21%	
1981	550.12	550.12	509.42	0.00	0.00	0.00	0.00	0.00	7.40%	
1982	402.23	402.23	372.31	0.00	0.00	0.00	0.00	0.00	7.44%	
1983	614.59	611.79	540.95	0.00	0.00	0.00	0.00	0.00	11.98%	
1984	872.99	863.99	803.09	0.00	0.00	0.00	0.00	0.00	8.01%	
1985	1,370.77	1,349.23	1,310.23	0.76	0.00	2.03	0.42	0.00	4.42%	
1986	1,732.24	1,717.22	1,626.22	0.75	0.00	1.94	0.40	0.00	6.12%	
1987	1,949.03	1,933.33	1,824.19	0.00	0.00	0.00	0.00	0.00	6.41%	
1988	1,717.70	1,705.74	1,602.24	0.00	0.00	0.00	0.00	0.00	6.72%	
1989	2,411.74	2,391.60	2,268.10	6.50	0.00	14.17	3.10	0.00	5.96%	
1990	2,319.26	2,312.76	2,180.81	41.60	0.00	85.68	19.09	0.00	146.37	5.97%
1991	3,400.02	3,365.02	3,147.49	43.33	0.00	84.08	19.12	0.00	146.53	7.43%
1992	3,457.68	3,451.46	3,246.58	44.52	0.00	81.01	18.84	0.00	144.37	6.11%
1993	4,151.28	4,124.93	3,906.68	45.36	0.00	77.11	18.36	0.00	140.83	5.89%
1994	4,910.56	4,855.43	4,605.22	56.12	0.00	88.69	21.72	0.00	166.53	6.22%
1995	5,884.36	5,799.19	5,529.65	77.16	0.00	112.31	28.42	0.00	217.89	6.03%
1996	6,738.82	6,645.17	6,271.91	144.05	0.00	192.55	50.48	0.00	387.08	6.93%
1997	7,592.65	7,510.25	7,111.42	44.44	0.00	54.22	14.79	0.00	113.45	6.34%
1998	7,560.06	7,436.38	7,033.57	9.02	0.00	9.92	2.84	0.00	21.78	6.96%
1999	9,654.50	9,373.29	8,941.17	9.02	0.00	8.84	2.68	0.00	20.54	7.39%
2000	14,526.69	12,334.02	11,867.38	46.71	0.00	40.16	13.03	0.00	99.90	18.31%
2001	13,596.71	10,912.83	10,345.13	133.54	0.00	98.81	34.84	0.00	267.19	23.91%
2002	15,561.68	13,181.15	12,625.06	123.07	0.00	76.28	29.90	0.00	229.25	18.87%
2003	25,163.21	20,961.93	20,137.20	375.17	0.00	187.46	112.53	0.00	675.16	19.97%
2004	33,167.86	28,142.00	26,964.23	768.00	0.00	290.74	211.77	0.00	1,270.51	18.70%
2005	58,030.77	39,673.45	37,262.38	1,977.38	0.00	513.48	498.18	0.00	2,989.04	35.79%
2006	1,431,847.44	152,928.18	130,910.96	21,831.94 ✓	0.00	1,893.33 ✓	70.48	0.00	23,795.75 ✓	90.86%
<b>TOTAL:</b>	<b>1,660,242.81</b>	<b>345,586.54</b>	<b>313,924.80</b>	<b>25,778.44</b>	<b>0.00</b>	<b>3,912.81</b>	<b>1,170.99</b>	<b>0.00</b>	<b>30,862.24 ✓</b>	<b>81.09%</b>
<b>DELINQUENT TOTAL DUE:</b>			<b>\$183,013.84</b>	<b>\$3,946.50 ✓</b>	<b>\$0.00</b>	<b>\$2,019.48 ✓</b>	<b>\$1,100.51</b>	<b>\$0.00</b>	<b>\$7,066.49</b>	

I, Martha Stone, Tax Collector for COUNTY certify that this is a true and correct report of all collections activities for this time period.

VOL II PG 756

05 STATE

	Yearly Beg Bal	Beg Bal	Total Due	Collected					Total Paid	% Collected
				Base Tax	Discount	Penalty	Attorny Fee	Other Payment		
1967	0.00	0.00	0.00	0.00	0.00	0.00	0.00	0.00	0.00	0.00%
1968	0.00	0.00	0.00	0.00	0.00	0.00	0.00	0.00	0.00	0.00%
1969	0.00	0.00	0.00	0.00	0.00	0.00	0.00	0.00	0.00	0.00%
1970	0.00	0.00	0.00	0.00	0.00	0.00	0.00	0.00	0.00	0.00%
1971	0.00	0.00	0.00	0.00	0.00	0.00	0.00	0.00	0.00	0.00%
1972	0.00	0.00	0.00	0.00	0.00	0.00	0.00	0.00	0.00	0.00%
1973	0.00	0.00	0.00	0.00	0.00	0.00	0.00	0.00	0.00	0.00%
1974	0.00	0.00	0.00	0.00	0.00	0.00	0.00	0.00	0.00	0.00%
1975	0.48	0.48	0.48	0.00	0.00	0.00	0.00	0.00	0.00	0.00%
1976	0.78	0.78	0.78	0.00	0.00	0.00	0.00	0.00	0.00	0.00%
1977	13.12	13.12	13.12	0.00	0.00	0.00	0.00	0.00	0.00	0.00%
1978	27.42	27.42	25.04	0.00	0.00	0.00	0.00	0.00	0.00	8.68%
1979	35.41	35.41	32.53	0.00	0.00	0.00	0.00	0.00	0.00	8.13%
1980	0.00	0.00	0.00	0.00	0.00	0.00	0.00	0.00	0.00	0.00%
1981	0.00	0.00	0.00	0.00	0.00	0.00	0.00	0.00	0.00	0.00%
1982	0.00	0.00	0.00	0.00	0.00	0.00	0.00	0.00	0.00	0.00%
1983	0.00	0.00	0.00	0.00	0.00	0.00	0.00	0.00	0.00	0.00%
1984	0.00	0.00	0.00	0.00	0.00	0.00	0.00	0.00	0.00	0.00%
1985	0.00	0.00	0.00	0.00	0.00	0.00	0.00	0.00	0.00	0.00%
1986	0.00	0.00	0.00	0.00	0.00	0.00	0.00	0.00	0.00	0.00%
<b>TOTAL:</b>	77.21	77.21	71.95	0.00	0.00	0.00	0.00	0.00	0.00	6.81%
<b>DELINQUENT TOTAL DUE:</b>			\$71.95	\$0.00	\$0.00	\$0.00	\$0.00	\$0.00	\$0.00	

I, Maitha Stone, Tax Collector for STATE certify that this is a true and correct report of all collections activities for this time period.

VOL TT PG 757

49 - CED

Year	Beg Balance	Refunds	Adjustment	Base Tax	Discounts	P/I	Att'y Fee	Other Payment	Total Paid	Total Due
1991	\$0.00	\$0.00	\$0.00	\$0.00	\$0.00	\$0.00	\$0.00	\$0.00	\$0.00	\$0.00
1992	\$0.00	\$0.00	\$0.00	\$0.00	\$0.00	\$0.00	\$0.00	\$0.00	\$0.00	\$0.00
<b>TOTALS</b>	\$0.00	\$0.00	\$0.00	\$0.00	\$0.00	\$0.00	\$0.00	\$0.00	\$0.00	\$0.00
<b>CURRENTS</b>	\$0.00	\$0.00	\$0.00	\$0.00	\$0.00	\$0.00	\$0.00	\$0.00	\$0.00	\$0.00
<b>DELINQUENTS</b>	\$0.00	\$0.00	\$0.00	\$0.00	\$0.00	\$0.00	\$0.00	\$0.00	\$0.00	\$0.00

VOL II PG 758

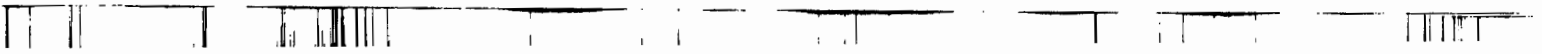

01 - COUNTY

Year	Beg Balance	Refunds	Adjustment	Base Tax	Discounts	P/I	Att'y Fee	Other Payment	Total Paid	Total Due
1967	\$0.00	\$0.00	\$0.00	\$0.00	\$0.00	\$0.00	\$0.00	\$0.00	\$0.00	\$0.00
1968	\$0.00	\$0.00	\$0.00	\$0.00	\$0.00	\$0.00	\$0.00	\$0.00	\$0.00	\$0.00
1969	\$0.00	\$0.00	\$0.00	\$0.00	\$0.00	\$0.00	\$0.00	\$0.00	\$0.00	\$0.00
1970	\$0.00	\$0.00	\$0.00	\$0.00	\$0.00	\$0.00	\$0.00	\$0.00	\$0.00	\$0.00
1971	\$0.00	\$0.00	\$0.00	\$0.00	\$0.00	\$0.00	\$0.00	\$0.00	\$0.00	\$0.00
1972	\$0.00	\$0.00	\$0.00	\$0.00	\$0.00	\$0.00	\$0.00	\$0.00	\$0.00	\$0.00
1973	\$0.00	\$0.00	\$0.00	\$0.00	\$0.00	\$0.00	\$0.00	\$0.00	\$0.00	\$0.00
1974	\$0.00	\$0.00	\$0.00	\$0.00	\$0.00	\$0.00	\$0.00	\$0.00	\$0.00	\$0.00
1975	\$3.20	\$0.00	\$0.00	\$0.00	\$0.00	\$0.00	\$0.00	\$0.00	\$0.00	\$3.20
1976	\$5.20	\$0.00	\$0.00	\$0.00	\$0.00	\$0.00	\$0.00	\$0.00	\$0.00	\$5.20
1977	\$105.00	\$0.00	\$0.00	\$0.00	\$0.00	\$0.00	\$0.00	\$0.00	\$0.00	\$105.00
1978	\$240.39	\$0.00	\$(19.04)	\$0.00	\$0.00	\$0.00	\$0.00	\$0.00	\$0.00	\$221.35
1979	\$283.28	\$0.00	\$(23.04)	\$0.00	\$0.00	\$0.00	\$0.00	\$0.00	\$0.00	\$260.24
1980	\$416.78	\$0.00	\$(30.56)	\$0.00	\$0.00	\$0.00	\$0.00	\$0.00	\$0.00	\$386.22
1981	\$550.12	\$0.00	\$(40.70)	\$0.00	\$0.00	\$0.00	\$0.00	\$0.00	\$0.00	\$509.42
1982	\$402.23	\$0.00	\$(29.92)	\$0.00	\$0.00	\$0.00	\$0.00	\$0.00	\$0.00	\$372.31
1983	\$611.79	\$0.00	\$(70.84)	\$0.00	\$0.00	\$0.00	\$0.00	\$0.00	\$0.00	\$540.95
1984	\$863.99	\$0.00	\$(60.90)	\$0.00	\$0.00	\$0.00	\$0.00	\$0.00	\$0.00	\$803.09
1985	\$1,349.23	\$0.00	\$(38.24)	\$0.76	\$0.00	\$2.03	\$0.42	\$0.00	\$3.21	\$1,310.23
1986	\$1,717.22	\$0.00	\$(90.25)	\$0.75	\$0.00	\$1.94	\$0.40	\$0.00	\$3.09	\$1,626.22
1987	\$1,933.33	\$0.00	\$(109.14)	\$0.00	\$0.00	\$0.00	\$0.00	\$0.00	\$0.00	\$1,824.19
1988	\$1,705.74	\$0.00	\$(103.50)	\$0.00	\$0.00	\$0.00	\$0.00	\$0.00	\$0.00	\$1,602.24
1989	\$2,391.60	\$0.00	\$(117.00)	\$6.50	\$0.00	\$14.17	\$3.10	\$0.00	\$23.77	\$2,268.10
1990	\$2,312.76	\$0.00	\$(90.35)	\$41.60	\$0.00	\$85.68	\$19.09	\$0.00	\$146.37	\$2,180.81
1991	\$3,365.02	\$0.00	\$(174.20)	\$43.33	\$0.00	\$84.08	\$19.12	\$0.00	\$146.53	\$3,147.49
1992	\$3,451.46	\$0.00	\$(160.36)	\$44.52	\$0.00	\$81.01	\$18.84	\$0.00	\$144.37	\$3,246.58
1993	\$4,124.93	\$0.00	\$(172.89)	\$45.36	\$0.00	\$77.11	\$18.36	\$0.00	\$140.83	\$3,906.68
1994	\$4,855.43	\$0.00	\$(194.09)	\$56.12	\$0.00	\$88.69	\$21.72	\$0.00	\$166.53	\$4,605.22
1995	\$5,799.19	\$0.00	\$(192.38)	\$77.16	\$0.00	\$112.31	\$28.42	\$0.00	\$217.89	\$5,529.65
1996	\$6,645.17	\$0.00	\$(229.21)	\$144.05	\$0.00	\$192.55	\$50.48	\$0.00	\$387.08	\$6,271.91
1997	\$7,510.25	\$0.00	\$(354.39)	\$44.44	\$0.00	\$54.22	\$14.79	\$0.00	\$113.45	\$7,111.42
1998	\$7,436.38	\$0.00	\$(393.79)	\$9.02	\$0.00	\$9.92	\$2.84	\$0.00	\$21.78	\$7,033.57
1999	\$9,373.29	\$0.00	\$(423.10)	\$9.02	\$0.00	\$8.84	\$2.68	\$0.00	\$20.54	\$8,941.17
2000	\$12,334.02	\$0.00	\$(419.93)	\$46.71	\$0.00	\$40.16	\$13.03	\$0.00	\$99.90	\$11,867.38
2001	\$10,912.83	\$0.00	\$(434.16)	\$133.54	\$0.00	\$98.81	\$34.84	\$0.00	\$267.19	\$10,345.13
2002	\$13,181.15	\$0.00	\$(433.02)	\$123.07	\$0.00	\$76.28	\$29.90	\$0.00	\$229.25	\$12,625.06
2003	\$20,961.93	\$0.00	\$(449.56)	\$375.17	\$0.00	\$187.46	\$112.53	\$0.00	\$675.16	\$20,137.20
2004	\$28,142.00	\$0.00	\$(409.77)	\$768.00	\$0.00	\$290.74	\$211.77	\$0.00	\$1,270.51	\$26,964.23
2005	\$39,673.45	\$0.00	\$(433.69)	\$1,977.38	\$0.00	\$513.48	\$498.18	\$0.00	\$2,989.04	\$37,262.38
2006	\$152,928.18	\$0.00	\$(185.28)	\$21,831.94	\$0.00	\$1,893.33	\$70.48	\$0.00	\$23,795.75	\$130,910.96

VOL II PG 759

FROM 3/1/2007 TO 3/31/2007

TOTALS	\$345,586.54	\$0.00	(\$5,883.30)	\$25,778.44	\$0.00	\$3,912.81	\$1,170.99	\$0.00	\$30,862.24 ✓	\$313,924.80
CURRENTS	\$152,928.18	\$0.00	(\$185.28)	\$21,831.94	\$0.00	\$1,893.33	\$70.48	\$0.00	\$23,795.75 ✓	\$130,910.96
DELINQUENTS	\$192,658.36	\$0.00	(\$5,698.02)	\$3,946.50	\$0.00	\$2,019.48	\$1,100.51	\$0.00	\$7,066.49 ✓	\$183,013.84

VOL IT pg 760



05 - STATE

Year	Beg Balance	Refunds	Adjustment	Base Tax	Discounts	P/I	Att'y Fee	Other Payment	Total Paid	Total Due
1967	\$0.00	\$0.00	\$0.00	\$0.00	\$0.00	\$0.00	\$0.00	\$0.00	\$0.00	\$0.00
1968	\$0.00	\$0.00	\$0.00	\$0.00	\$0.00	\$0.00	\$0.00	\$0.00	\$0.00	\$0.00
1969	\$0.00	\$0.00	\$0.00	\$0.00	\$0.00	\$0.00	\$0.00	\$0.00	\$0.00	\$0.00
1970	\$0.00	\$0.00	\$0.00	\$0.00	\$0.00	\$0.00	\$0.00	\$0.00	\$0.00	\$0.00
1971	\$0.00	\$0.00	\$0.00	\$0.00	\$0.00	\$0.00	\$0.00	\$0.00	\$0.00	\$0.00
1972	\$0.00	\$0.00	\$0.00	\$0.00	\$0.00	\$0.00	\$0.00	\$0.00	\$0.00	\$0.00
1973	\$0.00	\$0.00	\$0.00	\$0.00	\$0.00	\$0.00	\$0.00	\$0.00	\$0.00	\$0.00
1974	\$0.00	\$0.00	\$0.00	\$0.00	\$0.00	\$0.00	\$0.00	\$0.00	\$0.00	\$0.00
1975	\$0.48	\$0.00	\$0.00	\$0.00	\$0.00	\$0.00	\$0.00	\$0.00	\$0.00	\$0.48
1976	\$0.78	\$0.00	\$0.00	\$0.00	\$0.00	\$0.00	\$0.00	\$0.00	\$0.00	\$0.78
1977	\$13.12	\$0.00	\$0.00	\$0.00	\$0.00	\$0.00	\$0.00	\$0.00	\$0.00	\$13.12
1978	\$27.42	\$0.00	\$(2.38)	\$0.00	\$0.00	\$0.00	\$0.00	\$0.00	\$0.00	\$25.04
1979	\$35.41	\$0.00	\$(2.88)	\$0.00	\$0.00	\$0.00	\$0.00	\$0.00	\$0.00	\$32.53
1980	\$0.00	\$0.00	\$0.00	\$0.00	\$0.00	\$0.00	\$0.00	\$0.00	\$0.00	\$0.00
1981	\$0.00	\$0.00	\$0.00	\$0.00	\$0.00	\$0.00	\$0.00	\$0.00	\$0.00	\$0.00
1982	\$0.00	\$0.00	\$0.00	\$0.00	\$0.00	\$0.00	\$0.00	\$0.00	\$0.00	\$0.00
1983	\$0.00	\$0.00	\$0.00	\$0.00	\$0.00	\$0.00	\$0.00	\$0.00	\$0.00	\$0.00
1984	\$0.00	\$0.00	\$0.00	\$0.00	\$0.00	\$0.00	\$0.00	\$0.00	\$0.00	\$0.00
1985	\$0.00	\$0.00	\$0.00	\$0.00	\$0.00	\$0.00	\$0.00	\$0.00	\$0.00	\$0.00
1986	\$0.00	\$0.00	\$0.00	\$0.00	\$0.00	\$0.00	\$0.00	\$0.00	\$0.00	\$0.00
<b>TOTALS</b>	\$77.21	\$0.00	\$(5.26)	\$0.00	\$0.00	\$0.00	\$0.00	\$0.00	\$0.00	\$71.95
<b>CURRENTS</b>	\$0.00	\$0.00	\$0.00	\$0.00	\$0.00	\$0.00	\$0.00	\$0.00	\$0.00	\$0.00
<b>DELINQUENTS</b>	\$77.21	\$0.00	\$(5.26)	\$0.00	\$0.00	\$0.00	\$0.00	\$0.00	\$0.00	\$71.95

VOL 11 PG 261



01 COUNTY

Posting Date	Base Tax	Discounts	Penalty/Interest	Attmry Fee	Other Payment	Total Amount
03/01/2007	\$1,682.05	\$0.00	\$261.27	\$82.51	\$0.00	\$2,025.83
03/02/2007	\$1,109.51	\$0.00	\$118.76	\$26.88	\$0.00	\$1,255.15
03/05/2007	\$1,249.08	\$0.00	\$146.24	\$46.06	\$0.00	\$1,441.38
03/06/2007	\$613.85	\$0.00	\$83.68	\$41.47	\$0.00	\$739.00
03/07/2007	\$700.47	\$0.00	\$66.13	\$4.62	\$0.00	\$771.22
03/08/2007	\$1,026.63	\$0.00	\$88.26	\$8.26	\$0.00	\$1,123.15
03/09/2007	\$1,284.14	\$0.00	\$402.83	\$246.92	\$0.00	\$1,933.89
03/12/2007	\$1,612.12	\$0.00	\$731.01	\$162.49	\$0.00	\$2,505.62
03/13/2007	\$375.69	\$0.00	\$33.81	\$0.00	\$0.00	\$409.50
03/14/2007	\$1,521.10	\$0.00	\$309.30	\$144.02	\$0.00	\$1,974.42
03/15/2007	\$586.34	\$0.00	\$71.28	\$25.99	\$0.00	\$683.61
03/16/2007	\$1,207.83	\$0.00	\$121.03	\$18.27	\$0.00	\$1,347.13
03/19/2007	\$1,096.26	\$0.00	\$98.69	\$0.00	\$0.00	\$1,194.95
03/20/2007	\$783.49	\$0.00	\$116.42	\$52.13	\$0.00	\$952.04
03/21/2007	\$624.73	\$0.00	\$101.96	\$46.20	\$0.00	\$772.89
03/22/2007	\$922.99	\$0.00	\$91.12	\$5.65	\$0.00	\$1,019.76
03/23/2007	\$2,012.23	\$0.00	\$323.06	\$156.25	\$0.00	\$2,491.54
03/26/2007	\$1,144.12	\$0.00	\$156.14	\$22.49	\$0.00	\$1,322.75
03/27/2007	\$1,557.70	\$0.00	\$161.02	\$44.23	\$0.00	\$1,762.95
03/28/2007	\$747.20	\$0.00	\$80.45	\$8.17	\$0.00	\$835.82
03/29/2007	\$1,511.53	\$0.00	\$141.01	\$13.36	\$0.00	\$1,665.90
03/30/2007	\$2,409.38	\$0.00	\$209.34	\$15.02	\$0.00	\$2,633.74
<b>TOTALS</b>	<b>\$25,778.44</b>	<b>\$0.00</b>	<b>\$3,912.81</b>	<b>\$1,170.99</b>	<b>\$0.00</b>	<b>\$30,862.24</b> ✓

I, MARTHA M. STONE Of SABINE COUNTY TAX OFFICE, do solemnly swear the the Summary of Collection made above, during 3/1/2007 To 3/31/2007, is true and correct.

SABINE COUNTY TAX OFFICE  
 MARTHA M. STONE Martha Stone  
 Deputy \_\_\_\_\_  
 Subscribed and sworn to before me this 5 day of April, 2007  
 Notary Public \_\_\_\_\_

VOL IT PG 762

**Martha Stone, TAC**  
**SABINE COUNTY**  
**TAX ASSESSOR/COLLECTOR**  
**March 2007**

COUNTY FEES:	RECEIPTS	COUNTY DISBURSEMENTS	OTHER DISBURSEMENTS
AD VALOREM	23,725.57	23,725.27	
DEL. AD VALOREM	3,946.50	3,946.50	
AD VALOREM P&I	2,019.48	2,019.48	
Co.Add'l Penalty	1,170.99		1,170.99
HOSPITAL	12,687.22	126.86	12,560.36
DEL. HOSPITAL	1,253.67	12.53	1,241.14
HOSPITAL P & I	586.11	5.86	580.25
Hospital Add'l Penalty	376.30		376.30
HEMPHILL ISD	58,533.95	585.33	57,948.62
DEL. HEMPHILL ISD	9,501.32	95.01	9,406.31
HEMPHILL ISD P & I	5,377.33	53.77	5,323.56
Hemphill Add'l Penalty	2,903.10		2,903.10
PINELAND CITY	521.08		521.08
DEL PINELAND CITY	196.34		196.34
PINELAND CITY P & I	131.80		131.80
Pineland Add'l Penalty	56.51		56.51
WEST SABINE ISD	8,949.31		8,949.31
DEL. WEST SABINE ISD	2,993.45		2,993.45
WEST SABINE P & I	1,294.31		1,294.31
West Sabine Add'l Penalty	837.86		837.86
TAX CERTIFICATES	10.00	5.00	5.00
COPIES	15.50	15.50	
COUNTY ALCOHOL			
COUNTY OTHER			
NSF FEES	55.00	55.00	
BOAT & MOTOR REG.	5,690.00	569.00	5,121.00
COUNTY INTEREST	566.71	566.71	
COURT COSTS/AB FEES	1,273.09	883.38	389.71
COCA COLA COMM.			
<b>TOTALS:</b>	<b>\$ 144,672.50</b>	<b>\$ 32,665.20</b>	<b>\$ 112,007.00</b>
<b>DEALER TAXES:</b>			
VIT/BIT			
DEALER INTEREST	1.91	1.91	
<b>TOTALS:</b>	<b>\$ 1.91</b>	<b>\$ 1.91</b>	<b>\$ -</b>
<b>SALES TAX FEES:</b>			
BOAT & MOTOR	4,482.36	224.12	4,258.24
MOTOR VEHICLE	38,118.43		38,118.43
REG. SURCHARGE	50.00		50.00
TERP TITLE FEES	3,058.54		3,058.54
1% SURCHARGE			
2.5% SURCHARGE			
<b>TOTALS:</b>	<b>\$ 45,709.33</b>	<b>\$ 224.12</b>	<b>\$ 45,485.21</b>
<b>STATE FEES:</b>			
REGISTRATION	67,183.50	52,676.00	1,317.25
ROAD & BRIDGE	11,720.00	10,039.50	310.00
TITLE APPLICATIONS	1,820.00	695.00	1,112.00
YOUNG FARMERS	175.00		175.00
REG EMISSIONS	55.23		55.23
IRP REGISTRATION	961.30	958.70	2.60
IRP ROAD & BRIDGE	40.00	38.80	1.20
STATE ALCOHOL			
STATE INTEREST	74.74	74.74	
<b>TOTALS:</b>	<b>\$ 82,029.77</b>	<b>\$ 64,482.74</b>	<b>\$ 2,973.28</b>
<b>COMPLETE TOTAL</b>	<b>\$ 272,413.51</b>	<b>\$ 97,373.97</b>	<b>\$ 160,465.49</b>

VOL II PG 763

# CERTIFICATE *of* COURSE COMPLETION

## Public Information Act

I, **Martha Stone**, certify that I have completed a course of training on the Texas Public Information Act that satisfies the legal requirements of Government Code, Section 552.012.

Certificate is issued effective this 28th day of March, 2007.



**ATTORNEY GENERAL OF TEXAS**  
**GREG ABBOTT**

*NOTICE TO CERTIFICATE HOLDER: You are responsible for the safekeeping of this document as evidence that you have completed this open government training course. The Office of the Attorney General does not maintain a record of course completion for you and is unable to issue duplicate certificates. Government Code Section 552.012(e) requires the governmental body with which you serve to maintain this Certificate of Course Completion and make it available for public inspection.*

Certificate No.: 07-85984P

VOL III PG 764

# CERTIFICATE *of* COURSE COMPLETION

## Open Meetings Act

I, **Martha Stone**, certify that I have completed a course of training on the Texas Open Meetings Act that satisfies the legal requirements of Government Code, Section 551.005.

Certificate is issued effective this 3rd day of April, 2007.



**ATTORNEY GENERAL OF TEXAS**  
**GREG ABBOTT**

*NOTICE TO CERTIFICATE HOLDER: You are responsible for the safekeeping of this document as evidence that you have completed this open government training course. The Office of the Attorney General does not maintain a record of course completion for you and is unable to issue duplicate certificates. Government Code Section 551.005(c) requires the governmental body with which you serve to maintain this Certificate of Course Completion and make it available for public inspection.*

Certificate No.: 07-86323M

VOL III PG 765

**NOTICE TO BIDDERS FOR  
DEPOSITORY OF FUNDS OF  
SABINE COUNTY, TEXAS**

Notice is hereby given that the Commissioners Court of Sabine County shall meet in regular session at 8:30 a.m. March 29, 2007 at their regular meeting place in the County Courthouse of Sabine County, Texas, at which time sealed proposals will be opened from banking corporations in Sabine County, Texas, desiring to be selected as depository of the funds of Sabine County, Texas and the funds of such political subdivisions of Sabine County as under the law are permitted to deposit in the County Depository of Sabine County, Texas and the political subdivisions of Sabine County, Texas for a term of one year commencing

Proposals will be accepted under the provisions of the State Statutes, Article XVI, Section 10 and pertaining to Article XVI, Sections 10 and 11, Texas Local Government Code.

All proposals submitted must specify the rate to be paid for the services.

Proposals must be sealed and plainly marked "Depository Proposal" and provided to James McDaniel, Sabine County Clerk, no later than 8:30 a.m. March 29, with final approval of proposals to be taken in Commissioners Court on April 9, 2007. Proposals may be withdrawn at any time prior to official opening.

The Commissioners Court of Sabine County reserves the right to reject in part, or in whole, any or all bids, waive minor technicalities, and award the proposal which best serves the interest of the County.

VOL IT PS 766

Notice to Customers: The purchase of an Indemnity Bond will be required before any official check of this Bank will be replaced or refunded in the event it is lost, misplaced or stolen.

# First State Bank

028276

P.O. Box 1944

Hempstead, Texas 75948-1944

MEMBER F.D.I.C.

REMITTER

**FIRST STATE BANK**

DATE **MARCH 26, 2007**

PAY TO THE ORDER OF **SABINE COUNTY**

\$ **5,000.00**

**FIVE THOUSAND AND 00/100**

DOLLARS

**Cashier's Check**

*Robert H. Russell*

AUTHORIZED SIGNATURE

DEPOSITORY BID - COUNTY & DISTRICT CLERK

⑈028276⑈ ⑆113122082⑆

⑈4005005⑈

VOL IT PG 767

# First State Bank

P.O. Box 1944  
Hemphill, Texas 75948-1944

MEMBER FDIC

TELEPHONE: 409 / 787-3361

March 22, 2007

DEPOSITORY OF THE SPECIAL  
FUNDS OF THE COUNTY AND  
DISTRICT CLERK

The Honorable  
The Commissioners Court  
Sabine County Courthouse  
Hemphill, Texas

Gentlemen:

This letter will serve as our formal application under Texas Civil Statutes, Article 2544 and those following pertaining to County Depositories and Section 116 and 117, Texas Local Government Code to serve as the Depository of the Special Funds of the County and District Clerk for the two year or four year period beginning May 1, 2007.

The Capital Stock of this bank is in the amount \$600,000.00 and the Certified Surplus is \$3,800,000.00. We enclose a statement of Financial Condition of the bank as of December 31, 2006 and a statement of even date with this application.

In accordance with Section 1 of Article 2558-a of the Texas Revised Civil Statutes, we attach our certified check in an amount not less than one-half of one percent (1/2 of 1%) of the average daily balances of the amount of Special Funds in the possessions of the Clerks during the proceeding calendar year as a guarantee of the good faith on the part of the bank that if the latter is accepted as the Depository of the funds of Sabine County, Texas it will comply with the provisions of the Article 2558-a and qualify by pledging securities as required by Section 3 of Article 2558-a and Article 2547 of the Texas Revised Civil Statutes.

In meeting the requirements of Section 3 of Article 2558-a and the requirements of Article 2547, the bank will pledge securities of the type and in the amount required by Section (C) of Article 2547.

The bank proposes to serve as your depository bank during the next four years in the same manner that we have served you in the past and agree to the following:

- (1) All funds of the County will be deposited in "Demand Deposit" or "Time Deposit" accounts at the bank. "Demand Deposits" will earn interest at a rate which will adjust on the first business day of each calendar quarter and be equal to the yield stated in the Wall Street Journal on the Treasury Bills maturing 26 weeks from the date of the latest auction proceeding said reset date (current yield on 26-week Treasury Bill is 4.910%). Interest

VOL III PG 768

will be computed on the daily ledger balance and paid monthly, however such interest paid shall never be less than four percent (4.00%) per annum.

- (2) "Time Deposit" accounts will be paid the posted rates of the bank, as posted in the lobby daily, however, interest paid on "Time Deposits" of the County will never be less than four percent (4.00%) per annum.

The current rates being paid on time Certificates of Deposit at the bank are as follows.

<u>Maturity</u>	<u>Rate (APR)</u>	<u>Annual Yield (APY)</u>
90 Day	3.15	3.19
180 Day	3.85	3.91
1 Year	4.70	4.78
2 Years	4.60	4.68
3 Years	4.50	4.57
4 Years	4.50	4.57
5 Years	5.00	5.09

- (3) The bank will charge an adjustable rate which will always be equal to 150 basis points (1.50%) below the Prime Rate as stated in the Wall Street Journal per annum (simple interest) from the date of payment and overdrafts of the County originating during the ensuing four-year period. The County will pay such overdrafts with proceeds from other sources within three (3) business days from payment of the overdraft. An overdraft is defined as a negative demand balance in the County accounts collectively, not by individual account.
- (4) The bank will make funds available to the County in the form of loans at a rate of interest in accordance with existing law and on financial terms to be negotiated at the time such loans are needed.
- (5) The bank offers its lobby services to the county free of any service charge to the extent such services rendered are requested for transacting the business of the County.

We are grateful for the privilege of handling the funds of the County and appreciate the opportunity to present this application. Thank you for your consideration. Our first and foremost aim is to provide Sabine County with a strong, independent institution offering the finest in banking services to its citizenry.

Very truly yours,



Robert Russell  
President

VOL II PG 769



**FIRST STATE BANK, HEMPHILL, TEXAS  
STATEMENT OF CONDITION  
DECEMBER 31, 2006  
(CONDENSED)**

**RESOURCES**

LOANS	\$ 9,317,884.79
CASH & DUE FROM BANKS	1,381,815.41
OBLIGATIONS OF THE U.S. GOV'T. AND ITS AGENCIES	31,358,175.07
MUNICIPAL AND CORPORATE BONDS AND OBLIGATIONS	2,774,390.79
OTHER BONDS & SECURITIES	1,034,355.27
BANKING HOUSE	169,909.92
FURNITURE & FIXTURES	87,548.91
FEDERAL FUNDS SOLD	5,600,000.00
OTHER ASSETS	637,480.82
	<b>\$ 52,359,543.78</b>

**LIABILITIES**

CAPITAL	\$ 600,000.00
SURPLUS	3,800,000.00
UNDIVIDED PROFITS	2,591,402.51
LESS: RESERVE FOR UNREALIZED GAIN ON SECURITIES	307,018.97
LOAN LOSS RESERVE	328,888.06
OTHER RESERVES	38,333.33
OTHER LIABILITIES	214,047.58
DEPOSITS	45,093,891.29
	<b>\$ 52,359,543.78</b>

**OFFICERS**

J. ROBERT HOWARD, CHAIRMAN OF THE BOARD, CEO  
LEE M. DUTTON, JR., PRESIDENT  
ROBERT H. RUSSELL, EXECUTIVE VICE PRESIDENT - OPERATIONS  
JUANICE VICKERS, EXECUTIVE VICE PRESIDENT - ADMINISTRATION  
TAMMIE COX, SENIOR VICE PRESIDENT - CASHIER  
CYNTHIA SMITH, VICE PRESIDENT - SECRETARY TO THE CHAIRMAN

**DIRECTORS**

J. ROBERT HOWARD  
LEE M. DUTTON, JR.  
O. D. HAMILTON  
WALLY KITTMAN

VIRGIL HAMMOCK  
WILLIAM A. SPEIGHTS  
MARTIN RUEFFER, D.D.S.  
ROBERT H. RUSSELL

VOL II PG 770

**FIRST STATE BANK, HEMPHILL, TEXAS  
STATEMENT OF CONDITION  
MARCH 22, 2007  
(CONDENSED)**

**RESOURCES**

LOANS	\$10,197,336.24
CASH & DUE FROM BANKS	2,370,697.28
OBLIGATIONS OF THE U.S. GOVT. AND ITS AGENCIES	32,547,876.30
MUNICIPAL AND CORPORATE BONDS AND OBLIGATIONS	1,823,069.14
OTHER BONDS & SECURITIES	1,034,355.27
BANKING HOUSE	172,540.38
FURNITURE & FIXTURES	84,169.48
FEDERAL FUNDS SOLD	4,700,000.00
OTHER ASSETS	583,825.81
	<b>\$ 53,513,869.91</b>

**LIABILITIES**

CAPITAL	\$ 600,000.00
SURPLUS	3,800,000.00
UNDIVIDED PROFITS	2,721,315.63
LESS: RESERVE FOR UNREALIZED GAIN ON SECURITIES	307,018.97
LOAN LOSS RESERVE	319,211.11
OTHER RESERVES	56.25
OTHER LIABILITIES	265,221.68
DEPOSITS	46,115,084.21
	<b>\$ 53,513,869.91</b>

**OFFICERS**

J. ROBERT HOWARD, CHAIRMAN OF THE BOARD, CEO  
ROBERT H. RUSSELL, PRESIDENT  
ARCHIE L. HOOD, EXECUTIVE VICE PRESIDENT - OPERATIONS  
JUANICE VICKERS, EXECUTIVE VICE PRESIDENT - ADMINISTRATION  
TAMMIE COX, SENIOR VICE PRESIDENT - CASHIER  
CYNTHIA SMITH, VICE PRESIDENT - SECRETARY TO THE CHAIRMAN

**DIRECTORS**

J. ROBERT HOWARD	VIRGIL HAMMOCK
ROBERT H. RUSSELL	WALLY KITTMAN
ARCHIE L. HOOD	WILLIAM A. SPEIGHTS
LEE M. DUTTON, JR.	MARTIN RUEFFER, D.D.S
O. D. HAMILTON	

VOL 17 PG 771

Notice to Customers: The purchase of an Indemnity Bond will be required before any official check of this Bank will be replaced or refunded in the event it is lost, misplaced or stolen.

# First State Bank

028277

P.O. Box 1946  
Hempstead, Texas 75943-1946

MEMBER F.D.I.C.

REMITTER

FIRST STATE BANK

DATE MARCH 26, 2007

PAY TO THE ORDER OF SABINE COUNTY

\$26,700.00

STATE BANK **26700** AND **00** CTS

DOLLARS

Cashier's Check

*Robert H. Russell*

AUTHORIZED SIGNATURE

DEPOSITORY BID - COUNTY FUNDS

⑈028277⑈

⑆13122082⑆

⑈4005005⑈

VOL II PG 772

# First State Bank

P.O. Box 1944  
Hemphill, Texas 75948-1944

MEMBER FDIC

TELEPHONE: 409 / 787-3361

March 22, 2007

DEPOSITORY OF THE FUNDS  
OF SABINE COUNTY, TEXAS

The Honorable  
The Commissioners Court  
Sabine County Courthouse  
Hemphill, Texas

Gentlemen:

This letter will serve as our formal application under Texas Civil Statutes, Article 2544 and those following pertaining to County Depositories and Section 116 and 117, Texas Local Government Code to serve as the Depository of the Funds of Sabine County, Texas for the two year or four year period beginning May 1, 2007.

The Capital Stock of this bank is in the amount \$600,000.00 and the Certified Surplus is \$3,800,000.00. We enclose a statement of Financial Condition of the bank as of December 31, 2006 and a statement of even date with this application.

In accordance with Article 2545-a of the Texas Revised Civil Statutes, we attach our Cashier's Check in an amount not less than one-half percent (1/2%) of the County Revenues for the proceeding year as a guarantee of the good faith on the part of the bank that if the latter is accepted as the Depository of the funds of Sabine County, Texas it will comply with the provisions of Article 2547 of the Statutes.

In meeting the requirements of Section 3 of Article 2547, the bank will pledge securities of the type and in the amount required by Section (C) of the cited Article

The bank proposes to serve as your depository bank during the next four years in the same manner that we have served you in the past and agree to the following:

- (1) All funds of the County will be deposited in "Demand Deposit" or "Time Deposit" accounts at the bank. "Demand Deposits" will earn interest at a rate which will adjust on the first business day of each calendar quarter and be equal to the yield stated in the Wall Street Journal on the Treasury Bills maturing 26 weeks from the date of the latest auction proceeding said reset date (current yield on 26-week Treasury Bill is 4.910%). Interest will be computed on the daily ledger balance and paid monthly, however such interest paid shall never be less than four percent (4.00%) per annum.

VOL 17 PG 773

- (2) "Time Deposit" accounts will be paid the posted rates of the bank, as posted in the lobby daily, however, interest paid on "Time Deposits" of the County will never be less than four percent (4.00%) per annum.

The current rates being paid on time Certificates of Deposit at the bank are as follows.

<u>Maturity</u>	<u>Rate (APR)</u>	<u>Annual Yield (APY)</u>
90 Day	3.15	3.19
180 Day	3.85	3.91
1 Year	4.70	4.78
2 Years	4.60	4.68
3 Years	4.50	4.57
4 Years	4.50	4.57
5 Years	5.00	5.09

- (3) The bank will charge an adjustable rate which will always be equal to 150 basis points (1.50%) below the Prime Rate as stated in the Wall Street Journal per annum (simple interest) from the date of payment and overdrafts of the County originating during the ensuing four-year period. The County will pay such overdrafts with proceeds from other sources within three (3) business days from payment of the overdraft. An overdraft is defined as a negative demand balance in the County accounts collectively, not by individual account.
- (4) The bank will make funds available to the County in the form of loans at a rate of interest in accordance with existing law and on financial terms to be negotiated at the time such loans are needed.
- (5) The bank offers its lobby services to the county free of any service charge to the extent such services rendered are requested for transacting the business of the County.

We are grateful for the privilege of handling the funds of the County and appreciate the opportunity to present this application. Thank you for your consideration. Our first and foremost aim is to provide Sabine County with a strong, independent institution offering the finest in banking services to its citizenry.

Very truly yours,

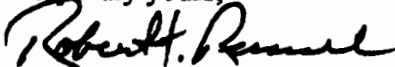

Robert Russell  
President

VOL TT PG 774

**FIRST STATE BANK, HEMPHILL, TEXAS  
STATEMENT OF CONDITION  
DECEMBER 31, 2006  
(CONDENSED)**

**RESOURCES**

LOANS	\$ 9,317,884.79
CASH & DUE FROM BANKS	1,381,815.41
OBLIGATIONS OF THE U.S. GOVT. AND ITS AGENCIES	31,356,175.07
MUNICIPAL AND CORPORATE BONDS AND OBLIGATIONS	2,774,390.79
OTHER BONDS & SECURITIES	1,034,355.27
BANKING HOUSE	189,909.92
FURNITURE & FIXTURES	87,548.91
FEDERAL FUNDS SOLD	5,600,000.00
OTHER ASSETS	637,480.62
	<b>\$ 52,359,543.78</b>

**LIABILITIES**

CAPITAL	\$ 600,000.00
SURPLUS	3,800,000.00
UNDIVIDED PROFITS	2,591,402.51
LESS: RESERVE FOR UNREALIZED GAIN ON SECURITIES	307,018.97
LOAN LOSS RESERVE	328,888.06
OTHER RESERVES	38,333.33
OTHER LIABILITIES	214,047.56
DEPOSITS	45,083,891.29
	<b>\$ 52,359,543.78</b>

**OFFICERS**

J. ROBERT HOWARD, CHAIRMAN OF THE BOARD, CEO  
LEE M. DUTTON, JR., PRESIDENT  
ROBERT H. RUSSELL, EXECUTIVE VICE PRESIDENT - OPERATIONS  
JUANICE VICKERS, EXECUTIVE VICE PRESIDENT - ADMINISTRATION  
TAMME COX, SENIOR VICE PRESIDENT - CASHIER  
CYNTHIA SMITH, VICE PRESIDENT - SECRETARY TO THE CHAIRMAN

**DIRECTORS**

J. ROBERT HOWARD  
LEE M. DUTTON, JR.  
O. D. HAMILTON  
WALLY KITTMAN

VIRGIL HAMMOCK  
WILLIAM A. SPEIGHTS  
MARTIN RUEFFER, D.D.S.  
ROBERT H. RUSSELL

VOL TT PG 775

**FIRST STATE BANK, HEMPHILL, TEXAS  
STATEMENT OF CONDITION  
MARCH 22, 2007  
(CONDENSED)**

**RESOURCES**

LOANS	\$10,197,336.24
CASH & DUE FROM BANKS	2,370,697.28
OBLIGATIONS OF THE U.S. GOV'T. AND ITS AGENCIES	32,547,876.30
MUNICIPAL AND CORPORATE BONDS AND OBLIGATIONS	1,823,069.14
OTHER BONDS & SECURITIES	1,034,355.27
BANKING HOUSE	172,540.38
FURNITURE & FIXTURES	84,169.48
FEDERAL FUNDS SOLD	4,700,000.00
OTHER ASSETS	583,825.81
	<b>\$ 53,513,869.91</b>

**LIABILITIES**

CAPITAL	\$ 600,000.00
SURPLUS	3,800,000.00
UNDIVIDED PROFITS	2,721,315.63
LESS: RESERVE FOR UNREALIZED GAIN ON SECURITIES	307,018.97
LOAN LOSS RESERVE	319,211.11
OTHER RESERVES	56.25
OTHER LIABILITIES	265,221.68
DEPOSITS	46,115,084.21
	<b>\$ 53,513,869.91</b>

**OFFICERS**

J. ROBERT HOWARD, CHAIRMAN OF THE BOARD, CEO  
ROBERT H. RUSSELL, PRESIDENT  
ARCHIE L. HOOD, EXECUTIVE VICE PRESIDENT - OPERATIONS  
JUANICE VICKERS, EXECUTIVE VICE PRESIDENT - ADMINISTRATION  
TAMMIE COX, SENIOR VICE PRESIDENT - CASHIER  
CYNTHIA SMITH, VICE PRESIDENT - SECRETARY TO THE CHAIRMAN

**DIRECTORS**

J. ROBERT HOWARD  
ROBERT H. RUSSELL  
ARCHIE L. HOOD  
LEE M. DUTTON, JR.  
O. D. HAMILTON

VIRGIL HAMMOCK  
WALLY KITTMAN  
WILLIAM A. SPEIGHTS  
MARTIN RUEFFER, D.D.S

VOL II PG 776

233309

REMITTER Sabine State Bank & Trust

84-205  
1111

DATE 03-23-07

PAY TO THE ORDER OF Sabine County

\$ 26,658.91

~~SABINE~~ \$26,658.91 CTS

2 SIGNATURES REQUIRED FOR AMOUNTS OVER \$2500.00



*Step Crowell*  
*Jean Harper*

⑈ 233309⑈ ⑆ 1111102059⑆

3454 ⑆⑈

VOL IT PG 777



**SABINE STATE BANK**  
**& Trust Company**

March 22, 2007

The Honorable Commissioner Court  
Sabine County Courthouse  
Hemphill, Texas

*HAND DELIVERED*

Gentlemen:

In response to the recently published bid notice, the Sabine State Bank and Trust Company is pleased to submit the following bid to serve as the depository for Sabine County, Texas, and the Court for a two- or four-year period.

Pursuant to Texas Revised Statutes, we herewith enclose a statement showing the financial condition of the Sabine State Bank and Trust Company on March 22. You will note that the Bank has outstanding Capital Common Stock of \$200,000 and a Permanent Surplus of \$14,781,000.

We understand that the County has approximately 25 deposit accounts. The Sabine Bank will pay interest on the collected balances on ALL of the County's accounts at a rate equivalent to the 180-day Treasury bill rate as published in *The Wall Street Journal* on the last day of the month plus 25 basis points; said rate to be adjusted on the first day of the month following thereafter. The rate for March would have been 5.18% under this scenario. In any event, the rate will not fall below 3.50% during the time of the contract.

None of the County's deposit accounts will receive a monthly service charge nor will there be any per item charges for deposits or withdrawals. The Bank will waive any fees incurred for inadvertent NSF/OD items provided that transfers sufficient to clear such NSF/OD items occur on the following business day.

Sabine State Bank is prepared to offer a \$1,500.00 credit to be applied to the cost of checks for the County. Also, the Bank will offer a 10% discount on any checks ordered through Sabine State Bank.

VOL IT PG 778

Sabine Bank will provide the County with a check reconciliation file in electronic format on a monthly basis should the County wish to automate its check reconciliation process. The Sabine Bank is prepared to provide the County a CD containing check images (front and back) on a monthly basis for easy storage and retention of information. Software required to view the images will be furnished at no charge.

The County will receive free internet and telephone banking capabilities allowing the County to review activity and the ability to transfer monies between County accounts.

Sabine Bank will offer free personal deposit accounts to County employees. Employees shall receive their first order of Sabine Program checks free and shall be eligible to receive an ATM card, debit card, internet banking, and telephone banking, all at no charge.

Interest rates paid for Certificates of Deposit, if requested, shall be at the U.S. Treasury Bill/Note rate for equivalent maturities plus 40 basis points or the Sabine State Bank stated rate, whichever is greater.

Sabine Bank also offers merchant credit card processing for the County's use. Transition to Sabine State Bank's merchant card processing will be without cost to the County.

The Sabine State Bank is prepared to offer various Automated Clearing House origination products to include direct deposit services for the County's payroll function.

Appropriate bank personnel would be glad to more thoroughly discuss any of the above functions at your convenience.

The County's banking relationship will be managed by Bank Vice President Stephen Crowell who will be assisted by Joan Harper. President Lee McCann, Senior Vice President and Public Finance Officer Stan Russell, and Public Funds Administrator Marianne Henson will also be available to provide support for the relationship.

Pursuant to the Texas Local Government Code, we herewith enclose our Bank Money Order in the sum of \$26,658.91 representing certified funds to serve as a "good-faith" guarantee on the part of Sabine State Bank that if we are accepted as the County Depository, we will comply with the statutory provisions requiring security for the County's public funds by pledging any or all of the following, to-wit:

- (1) bonds, notes, securities of indebtedness, or other evidence of indebtedness of the United States if the evidence of indebtedness is supported by the full faith and credit of the United States or is guaranteed as to principal and interest by the United States;
- (2) bonds of the state of Texas or a county, municipality, independent school district, or common school district;
- (3) bonds issued under the federal farm loan acts;

VOL IT PG 779

The Honorable Commissioner Court  
Sabine County  
March 22, 2007  
Page 3 of 3

- (4) road district bonds;
- (5) bonds, pledges, or other securities issued by the board of regents of The University of Texas System;
- (6) notes or bonds secured by mortgages insured and debentures issued by the Federal Housing Administration;
- (7) bonds issued by municipal corporations in the state of Texas.

The Sabine State Bank and Trust Company sincerely appreciates this opportunity to submit a bid to provide depository services for Sabine County and we look forward to working with the County. If you have any questions, please feel free to call upon us at (409) 787-1054.

Sincerely,

SABINE STATE BANK AND TRUST COMPANY



Stephen Crowell  
Vice President

VOL II PG 280

**SABINE STATE BANK & TRUST COMPANY**  
**Statement of Condition**  
**March 22, 2007**

<b>ASSETS</b>		
Cash & Due From Banks		28,514,251
Investment Securities		
United States & U.S. Agency Obligations	34,201,125	
Obligations of States and Political Subdivisions	104,300,323	
Other Securities	1,879,946	
Total Securities		140,381,394
Federal Funds Sold		5,000,000
Loans and Leases		
Net Loans	380,834,439	
Reserve for Bad Debts	(3,677,932)	
Net Loans		377,156,507
Other Receivables		3,865,601
Net Bank Premises and Equipment		8,527,941
Other Assets		4,593,831
<b>TOTAL ASSETS</b>		<b>568,039,525</b>
<b>LIABILITIES CAPITAL</b>		
Deposits		
Demand, Money Market, Savings, and Christmas Club Deposits	272,084,203	
Time Deposits Including IRA's	226,638,581	
Total Deposits		498,722,784
Treasury Tax and Loan Note		350,239
Repurchase Agreements and Other Borrowed Money		26,054,528
All Other Liabilities & Payables		2,811,394
<b>Total Liabilities</b>		<b>527,938,945</b>
Common Stock		200,000
Surplus		14,781,000
Undivided Profits & Other Reserves		25,119,580
<b>Total Capital</b>		<b>40,100,580</b>
<b>TOTAL LIABILITIES AND CAPITAL</b>		<b>568,039,525</b>

I hereby certify the foregoing to be the true state of condition of the Sabine State Bank and Trust Company as of the close of business on March 22, 2007.

*Alan J. Gougeon*  
 Vice President

**VOL II PG 781**

Columbia STS-107 Memorial  
Sabine County, Texas

Joshua 1: 6-9

*"THEIR MISSION BECAME OUR MISSION"*



Vol. II PG 782

Sabine County  
Eddings Lane  
Pct. 3

Doyle Dickerson  
Commissioner Pct.3  
PO Box 720  
Hemphill, TX 75948

Dear Doyle Dickerson,

This letter is to confirm and acknowledge that we have an agreement on the construction easement needed in the conjunction with the above County Road project. It is my desire to donate this permanent right-of-way so that the proposed county road construction may proceed in a timely fashion.

Therefore I would like to offer Sabine County a permanent right-of-way that will carry on with any land owner for 40 ft. wide and 2/10 mile long to straighten out a curve on Eddings Lane.

Sincerely,

*Arvie Gene Eddings*  
Arvie Gene Eddings - Owner

*Ophelia Z. Eddings*  
Ophelia Z. Eddings - Owner

3-28-07  
Date

3-28-07  
Date

VOL IT PG 783

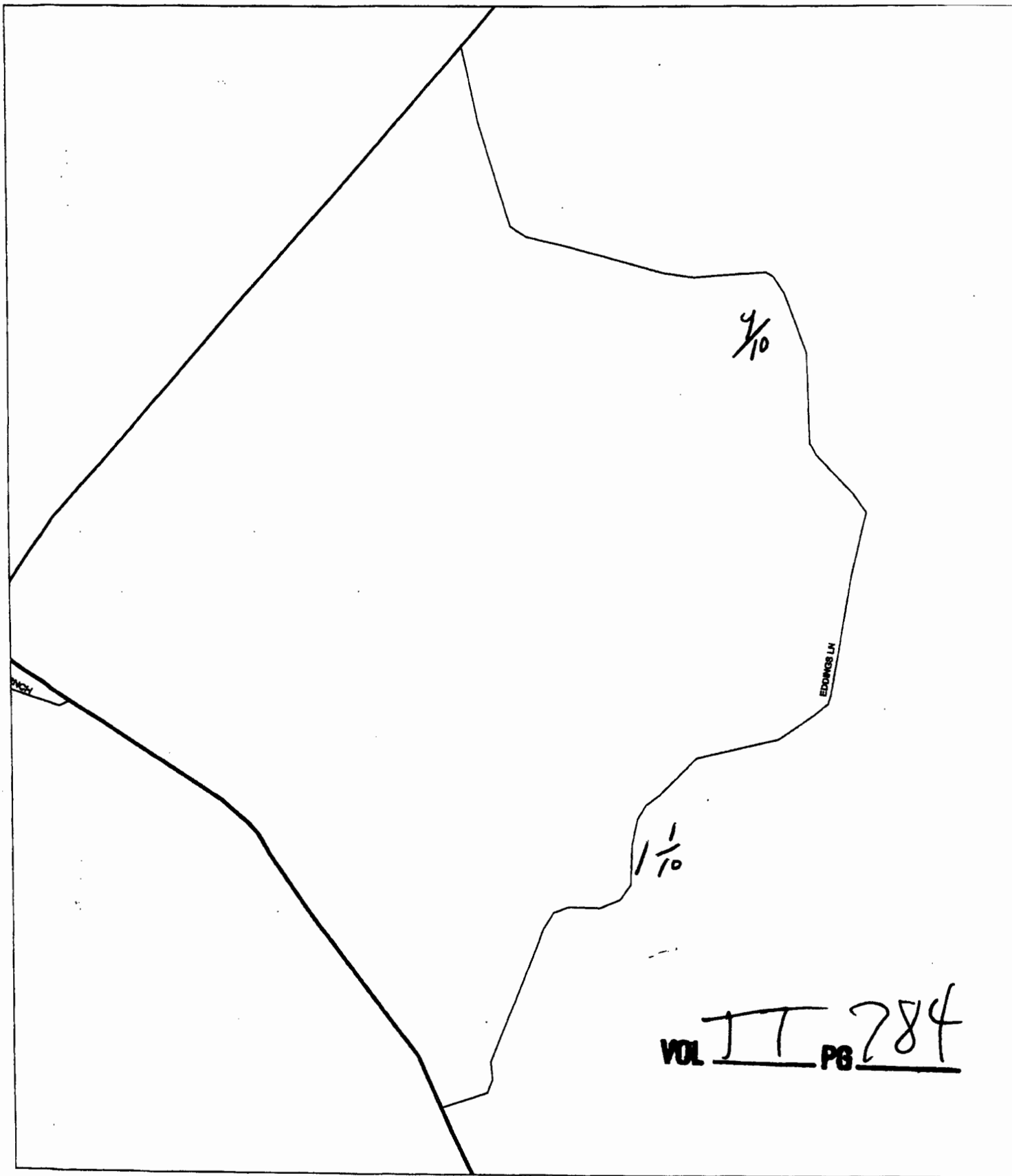

VOL IT PG 284







315 Spears Drive (409) 787-3278  
 Pineland, TX 75968 TACLB022514C

2139  
*Rejected*

3-23-07

- AIR FILTERS
  - CLEANED  REPLACED
- COMPRESSOR
  - SUCTION \_\_\_\_\_ PSI
  - HEAD \_\_\_\_\_ PSI
  - ELECTRICAL CONNECTIONS
  - CONTACTS TIGHT & CLEAN
  - CONDITION
- CONDENSATION AREAS
  - INSPECT & CLEAN DRAIN
- CONDENSER COIL
  - CLEAN COIL & CHECK FIN COND.
- ELECTRICAL COMPTS.
  - RELAYS  CONTACTORS
  - OVERLOAD  PRESS SWITCH
  - START CAPACITOR  RUN CAPACITOR
- FAN AND MOTOR
  - VOLTS \_\_\_\_\_ AMPS \_\_\_\_\_
  - ELECTRICAL CONNECTIONS
  - CONTACTS TIGHT & CLEAN
  - FAN PULLEYS (ADJUST BELT)
  - CHECK MOTOR
- HEATING ASSEMBLY
  - BURNER & HEAT EXCHANGER
  - FUEL SUPPLY & PRESSURE
- PILOT ASSEMBLY
  - FLAME ADJUSTMENT
- PRIMARY RELAY & FLUE
  - FAN & LIMIT SWITCH OPER.
  - BLOWER ASSEMBLY
  - RV VALVE
  - STRIP HEAT
  - DEFROST CYCLE
- REFRIGERANT
  - LEAK  CHARGE
- THERMOSTAT
  - O.K.  REPLACE

NAME Sabine Co Sheriff Dept  
 ADDRESS \_\_\_\_\_  
 CITY Hempstead STATE TX ZIP \_\_\_\_\_  
 JOB LOCATION \_\_\_\_\_

DATE ORDERED \_\_\_\_\_  
 DATE SCHEDULED \_\_\_\_\_  
 MAKE \_\_\_\_\_  
 MODEL \_\_\_\_\_  
 SERIAL NUMBER \_\_\_\_\_  
 PHONE \_\_\_\_\_  
 WK. PHONE \_\_\_\_\_

Road RENA-A060CL10E  
with Fresh AIR INTAKE  
curb adapter, and labor,  
and T-stat.  
County provides lift.

5650

REGULATED BY  
 STATE OF TEXAS  
 1-800-803-9202

<input type="checkbox"/> WARRANTY <input type="checkbox"/> CONTRACT <input type="checkbox"/> SERVICE CONTRACT <input type="checkbox"/> NORMAL <input type="checkbox"/> RES. <input type="checkbox"/> COMM. <input type="checkbox"/>	<b>LABOR QUARANTY</b> The labor charge as recorded here relative to the equipment serviced as noted, is guaranteed for a period of 30 days.		DESCRIPTION AMOUNT \$
	<b>PARTS WARRANTY</b> All parts as recorded are warranted as per manufacturer specifications.		
	We do not, of course, guarantee other parts than those we install. If repairs later become necessary due to other defective parts, they will be charged separately.		
	TOTAL PARTS		

TRAVEL TIME		MILEAGE		TOTAL OTHER CHARGES \$	LABOR CHARGES	HRS. @	A/R-
TIME ARRIVED	ENDING	X /NR.-		RECOMMENDED REPAIRS	TECHNICIAN SIGNATURE	CERTIFICATE NO.	
TIME DEPARTED	START -	X /NR.-			TOTAL OTHER CHARGES	I HEREBY AUTHORIZE THE ABOVE WORK TO BE DONE AS SO ORDERED AND OUTLINED ABOVE. IT IS AGREED THAT THE SELLER WILL RETAIN TITLE TO ANY EQUIPMENT OR MATERIAL FURNISHED UNTIL COMPLETE PAYMENT HAS BEEN MADE. IF SETTLEMENT IS NOT MADE AS AGREED, THE SELLER HAS THE RIGHT TO REMOVE EQUIPMENT AND MATERIAL WITHOUT BEING HELD RESPONSIBLE FOR ANY DAMAGES RESULTING FROM THE REMOVAL OF EQUIPMENT.	SUB-TOTAL
TRAVEL TIME	MILES	TMP	CHARGE \$				

INSPECTION CHECKLIST			
REFRIGERANT		EQUIPMENT	
NON USEABLE	TYPE	SYSTEM	CHANGED OUT (OR REPLACED)? YES NO
YES NO	REFRIG.	QTY.	DISMANTLED? YES NO
QTY.	RECOVERED?	YES NO	REFRIGERANT DISPOSAL
DISPOSAL	RECYCLED?	YES NO	OWNER'S INITIALS
	RECLAIMED?	YES NO	ACCEPTED DECLINED
	RETURNED TO THIS SYSTEM?	YES NO	

ABOVE ORDERED WORK HAS BEEN COMPLETED AND I ACKNOWLEDGE RECEIPT OF MY COPY.  
 X \_\_\_\_\_ DATE / /

April 9, 2007

SABINE COUNTY  
COMMISSIONER'S COURT  
HEMPHILL, TX 75948

TO: His Honor and the distinguished members of the Commissioner's  
Court

RE: "The Bean Burner", a Spark Arresting Incinerator

The purpose for my developing the above referenced incinerator was to create a container for clean and safe burning, particularly during burn bans, as fully described in the attached page, copied from the Provisional Patent Application as filed with the U.S. Patent Office.

My purpose for bringing the Incinerator to the attention of the Commissioner's Court is to demonstrate its capabilities and safety features and request approval from the Court to use the Incinerator during burn bans and, ultimately, to seek, through whatever legal channels necessary, certification from the Court an "Approved as Safe To Use During Burn Bans" on The Bean Burner, for marketing purposes.

Respectfully Submitted,

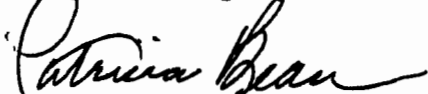

Patricia Bean  
390 Bragg Drive,  
Milam, TX 75959

409-625-3474

VOL II PG 787

IN THE UNITED STATES PATENT AND TRADEMARK OFFICE

- PROVISIONAL PATENT APPLICATION -

**SPARK ARRESTING INCINERATOR**

Field Of The Invention

The present invention generally relates to incinerators, and in its preferred embodiments more specifically relates to an incinerator structure that protects against the release of sparks or embers from the incinerator.

5 Background

Residents of rural areas often do not have access to garbage and trash disposal services or to landfills for disposal of their household garbage and trash. It is very common, therefore, for such residents to burn their household trash. During periods of drought or other periods when the surrounding vegetation is dry, fugitive sparks and embers from the burning of trash can pose a heightened risk of igniting surrounding vegetation. It is common for governmental authorities to impose restrictions on burning during such periods as a safety measure. Although burning restrictions are effective in limiting fires, they do create hardships for rural residents because of the accumulation of trash.

10 The present invention provides an incinerator apparatus designed for use at rural households and small business operations for the safe burning of trash and other combustible materials. The incinerator of the invention is designed to contain and control the combustion of such materials, and to prevent the emission of sparks or embers that could ignite vegetation or other combustible materials outside the incinerator.

VOL III PG 788

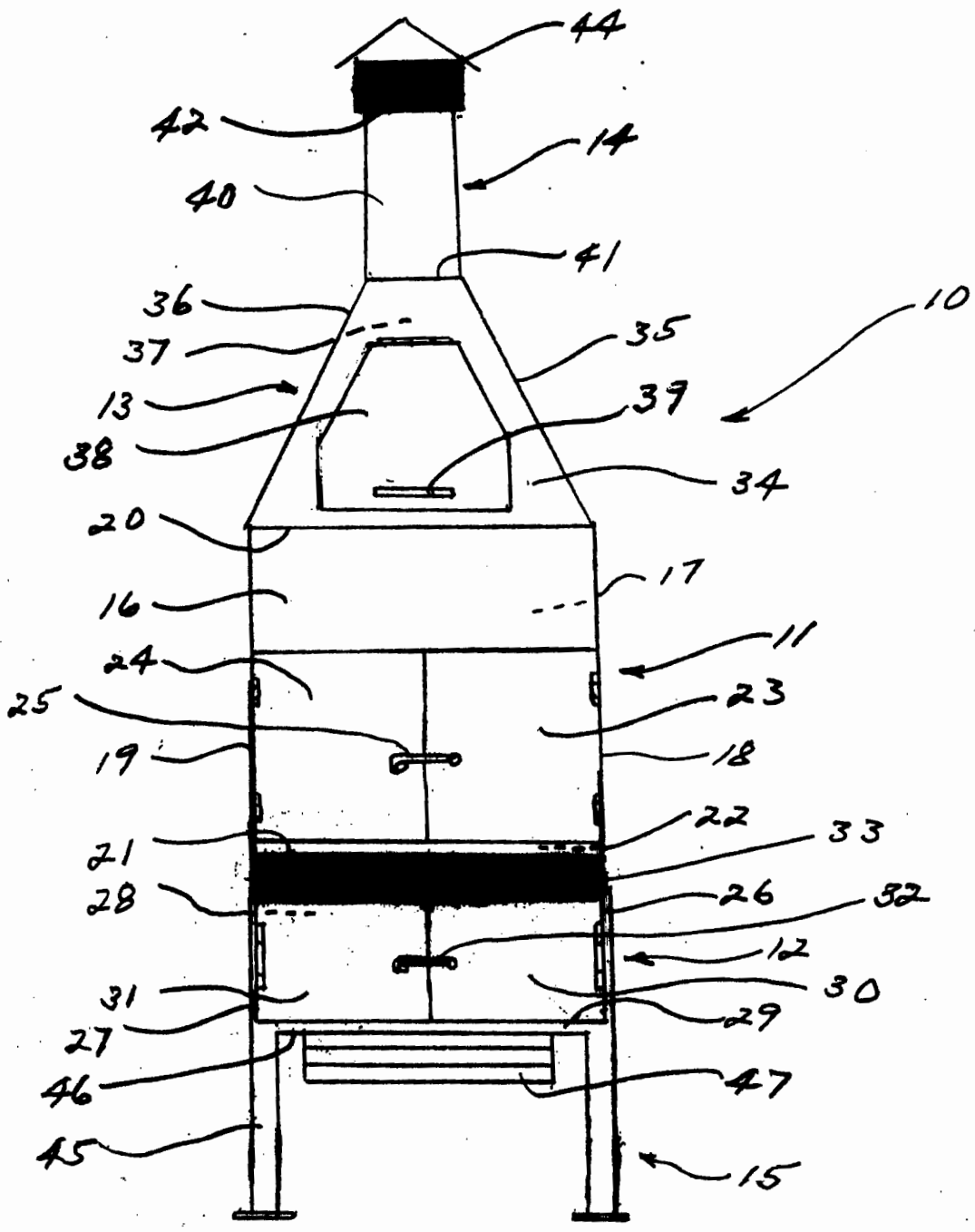

FIGURE 1

VOL II PG 789

Sabine County, Precinct 2, is accepting bids on surplus equipment:

1 Dura Patcher Model 125JDT with 300 gallon oil tank.

Bids are due by 8:30 a.m. April 23, 2007 with possible action taken during Commissioners' Court on April 23, 2007.

For further information contact Jimmy McDaniel, Commissioner, Pct. 2.

Sabine County reserves the right to accept or reject any/all bids.

Janice McDaniel/Sabine County Clerk

The State of Texas  
County of Sabine

I HEREBY CERTIFY THAT THESE DOCUMENTS WERE FILED AND  
DATE \_\_\_\_\_ IN THE COMMISSIONERS COURT MEETINGS OF SABINE  
COUNTY, TEXAS



VOL. TT PAGE 792  
JANICE MCDANIEL, COUNTY CLERK  
*Janice McDaniel*  
CLERK

VOL. TT PG. 790